

# KQWH/KQH系列单级立式/卧式化工泵

*KQWH / KQH Series Single-stage Vertical / Horizontal Chemical Pump*

➤ **The pump has the advantages of simple structure, strong reliability and convenient maintenance**

With special design structure, simple structure, small unit area, reliable use and convenient maintenance, it is a new generation of single-stage chemical pump

➤ **The blank parts of pump body, pump cover and impeller are made by precision casting**

High dimensional accuracy, smooth flow channel and beautiful appearance

➤ **The pump shaft adopts split shaft design and special clamping structure**

The damage to the motor shaft after corrosion of the pump shaft is fundamentally avoided, and the stable and reliable operation of the motor is ensured

➤ **Pump parts, the overall series of versatility**

Adopt the national standard vertical and horizontal motor and the series of pump cover, pump shaft, connecting frame and other parts, the whole series has the maximum versatility



# Catalogue

Product Overview.....	01
Product Use.....	01
Model Description.....	02
Type Spectrogram.....	04
Scope of Application.....	06
Material of Flow Passage Parts.....	06
Type of Shaft Seal.....	07
Example of Seal Model.....	07
Structural Features.....	08
Structural Diagram.....	09
Scope of Supply.....	11
Ordering Instructions.....	11
Performance Parameter Table.....	12
Characteristic Curve Graph.....	16
Outline and Installation Dimension Diagram of KQWH and KQWHD Horizontal Chemical Pump.....	28
Outline and Installation Dimension Table of KQWH Horizontal Chemical Pump.....	29
Outline and Installation Dimension Table of KQWHD Horizontal Chemical Pump.....	31
Outline and Installation Dimension Diagram of KQH and KQHD Vertical Chemical Pump.....	33
Outline and Installation Dimension Table of KQH Vertical Chemical Pump.....	34
Outline and Installation Dimension Table of KQHD Vertical Chemical Pump.....	36
Reference Table for Medium Selection of Chemical Pump.....	38

## Product Overview

KQWH and KQH series single-stage horizontal and single-stage vertical chemical pumps are based on the original chemical pumps, fully considering the particularity of structural requirements of chemical pumps in the process of use, and learning from advanced structural experience at home and abroad. The shaft adopts split shaft type and special clamping structure, which has the characteristics of simple structure, high concentricity, small vibration, reliable use and convenient maintenance. It is a new generation of single-stage chemical pump.

## Product Use

KQWH and KQH series chemical pumps can be applied to chemical industry, oil transportation, food, beverage, medicine, water treatment, environmental protection and some acid, alkali, salt and other application fields to a certain extent according to the specific use conditions of users. They are used to transport media with certain corrosivity, no solid particles or few particles, and viscosity similar to water. It is not recommended to be used in toxic, flammable, explosive and strongly corrosive situations.

### (1) Nitric acid and its application in nitric acid industry

In the process of nitric acid production by ammonia oxidation, the dilute nitric acid (50,60%) generated in the stainless steel absorption tower flows out from the bottom of the tower into the stainless steel storage tank and is transported to the next process by stainless steel pump. Attention should be paid to medium temperature and inlet pressure.

### (2) Phosphoric acid and its application in phosphoric acid industry

For pure acid, Cr13 stainless steel is only resistant to dilute acid, and 18-8 Cr Ni austenitic stainless steel is only resistant to dilute acid. The best phosphoric acid resistant material is Cr Ni Mo (0Cr18Ni12Mo2Ti) stainless steel.

However, for phosphoric acid production process, the material selection of pump is more complicated due to the existence of impurities in phosphoric acid, so we should be careful.

### (3) Application of sodium chloride and salt in salt water and sea water industry

Chromium nickel stainless steel has low uniform corrosion rate to neutral and slightly alkaline sodium chloride solution, seawater and brine at a certain temperature and concentration, so it is widely used. However, it should be noted that dangerous localized corrosion may occur in some cases.

Stainless steel pumps are widely used in the food industry to deal with salt water and salted food. However, attention should be paid to the problems of medium crystallization and mechanical seal selection.

### (4) Sodium hydroxide and its application in alkali industry

The Cr Ni austenitic stainless steel can resist about 80°C to 40% and 50% NaOH, but it is not resistant to high concentration of high temperature alkali.

Chromium stainless steel is only suitable for low temperature and low concentration alkaline solution.

Attention should be paid to the problem of medium crystallization.

### (5) Application in oil transportation

Attention should be paid to the viscosity of medium, material selection of rubber parts and explosion-proof requirements of motor.

### (6) Application in pharmaceutical industry

According to the delivery medium of the pump, the medical pump can be divided into the following two categories:

One is the common water pump, hot water pump and wastewater treatment system used in public works, and the other is the pump for conveying process media such as liquid medicine, intermediate, pure water, acid and alkali.

The former has lower requirements for pumps, which can be treated as pumps for general chemical plants, while the latter has higher requirements for pumps, which must meet the requirements of medical equipment.

Technical specification of centrifugal pump.

### (7) Application in food and beverage industry

In the food and beverage industry, the medium is not corrosive or less corrosive, but rust is not allowed, and the purity of the medium is very high. In this case, stainless steel pump can be selected.

## Model Description

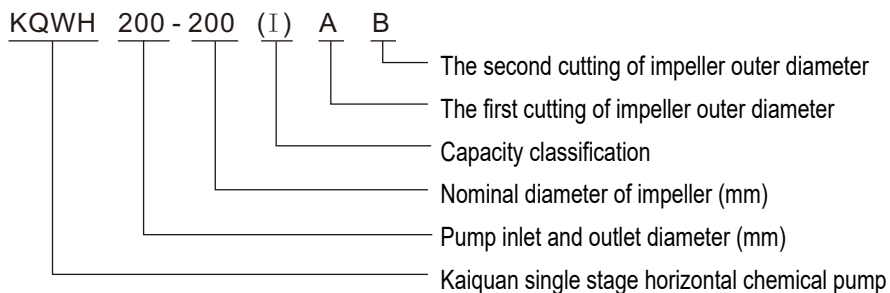
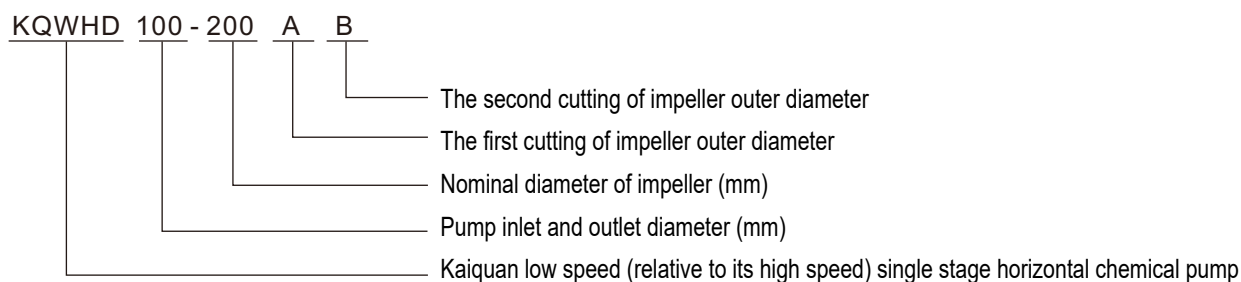
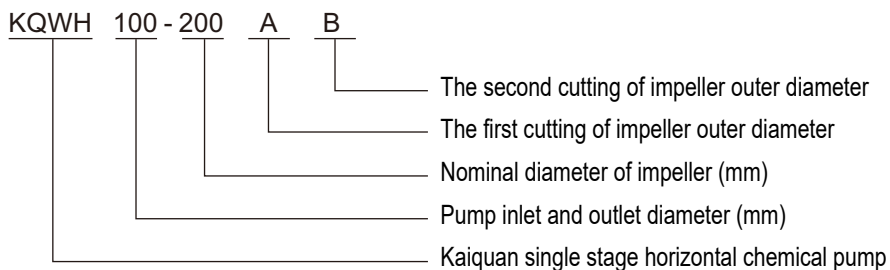

**Model Description**

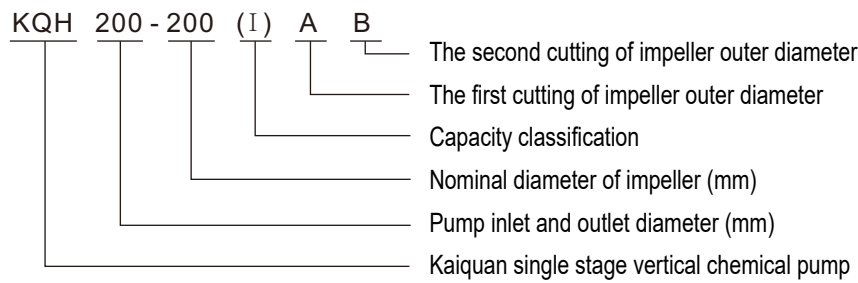
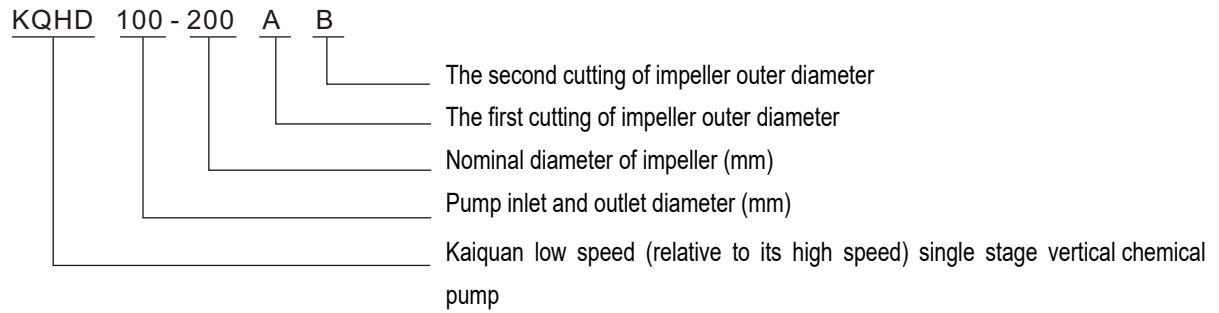
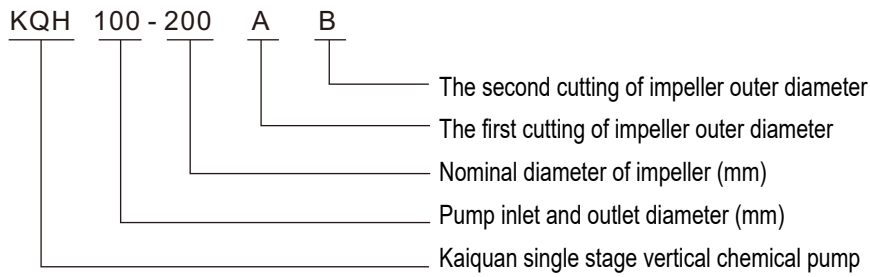

## Type Spectrogram

(Rotation Speed 2960 r / m i n )

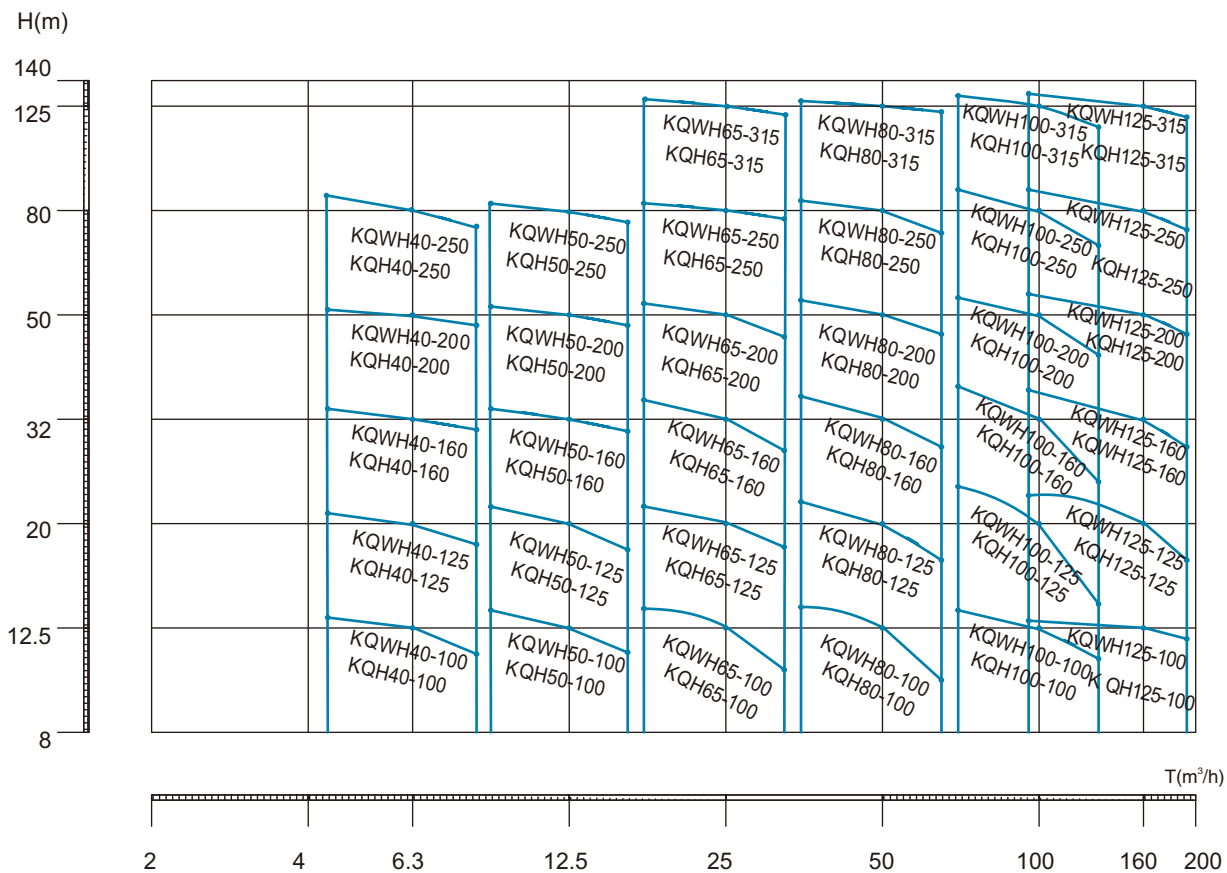

Type Spectrogram

(Rotation Speed 80 r/min)

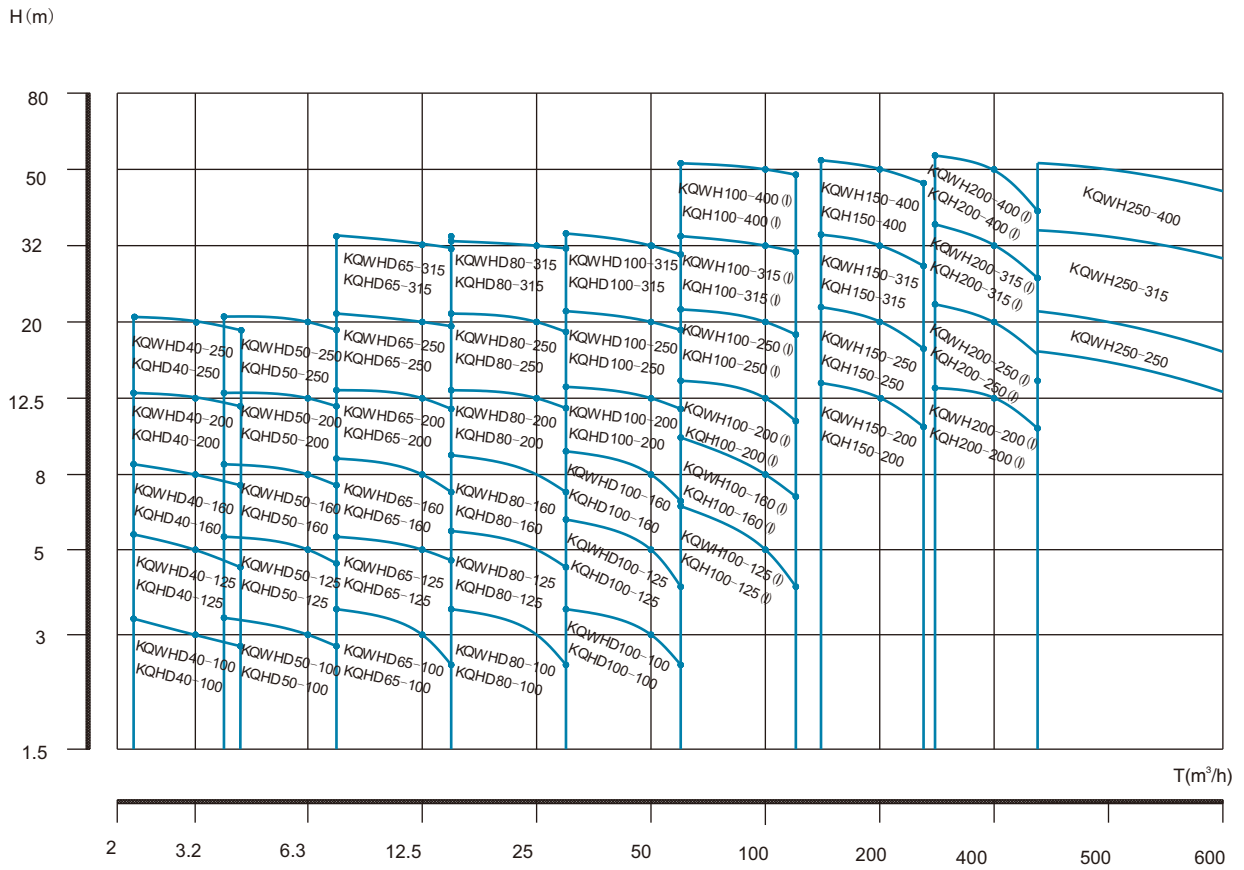

### Scope of Application

The series of pumps:

Capacity range: 2.2-480m<sup>3</sup>/h

Head range: 2.8-129m

Matching power: 0.55-90kw

Speed: 1480r/min and 2960r/min

Maximum working pressure: ≤ 1.6Mpa

Medium temperature: 10-80 ℃

Ambient temperature: up to 40 ℃

If the customer requests to exceed the above parameters, special supply can be made through negotiation.

### Material of Flow Passage Parts

#### 1. Basic material type

Casting material of flow passage parts: ZG0Cr18Ni9 or ZG0Cr17Ni12Mo2, etc.

The above material is the normal supply material of chemical pump of our company, which can be supplied according to the normal production cycle within the above material range.

#### 2. Optional material type (see the table below)

Casting material of flow passage parts:

ZG0Cr18Ni9、ZG0Cr17Ni12Mo2、ZG00Cr17Ni14Mo2
ZG0Cr18Ni9Ti

#### 3. Special type of material

Sometimes, according to the user's use conditions, the above materials can not meet the requirements of use. In this case, the material type needs to be determined.

Special material selection description:

It needs to be negotiated by both parties,

ZG1Cr13 and 2Cr13 stainless steel have good corrosion resistance in air and water vapor, and they are used in fresh water, sea water and salt at certain temperature

The corrosion resistance of water solution, nitric acid, food medium and organic acid, organic compound, salt, alkali and oil with low concentration is also sufficient. But the corrosion resistance of sulfuric acid, hydrochloric acid, hot phosphoric acid, hot nitric acid and molten contact alkali is very low.

The corrosion resistance of ZG0Cr18Ni9 and OCr18Ni9 is better than that of chromium steel, and the application range is wider.

The corrosion resistance of the above materials to different media is shown in Table 1 and table 2 attached to the sample.

Special notice: Due to the complexity and diversity of chemical media, if you have any questions when selecting materials, please consult the relevant department or technical support department of our company's technical center in detail.

## Type of Shaft Seal

M3N or MG1 rubber bellows mechanical seal is selected for this series of pumps according to specific service conditions.

Generally, M3N mechanical seal is widely used. It has high stability and good reliability, and is suitable for cleaning media without impurity particles. The mechanical seal can be applied to some acid, alkali, salt, oil, beverage and organic chemical media through different matching combinations of component materials.

MG1 mechanical seal is the most commonly used seal. It can be used in wastewater containing particles. It is not suitable for use in organic solvent medium.

According to the actual situation, the materials of mechanical seal components can be selected as follows:

(1) For M3N series rotating ring, the following materials can be selected:

Antimony impregnated graphite (A), resin impregnated graphite (B), inlaid pressureless sintered silicon carbide (Q12), inlaid reactive sintered silicon carbide (Q22), inlaid nickel based tungsten carbide (U22), etc.

Materials of stationary ring can be selected as follows:

Pressureless sintering silicon carbide (Q1), reaction sintering silicon carbide (Q2), etc

(2) For MG1 series rotating ring, the following materials can be selected:

Antimony impregnated graphite (A), resin impregnated graphite (B), pressureless sintered silicon carbide (Q1), etc.

Materials of stationary ring can be selected as follows:

Pressureless sintering of silicon carbide (Q1) and alumina ceramics (V).

(3) Auxiliary seal material can be selected as follows:

EPDM (E), NBR (P), Viton (V) and so on.

The application temperature range of NBR is  $-54^{\circ}\text{C}$  to  $+120^{\circ}\text{C}$ . It has excellent corrosion resistance to mineral oil, animal and vegetable oil and aliphatic hydrocarbon. It is resistant to alkali and oxidizing dilute acid corrosion. It can be used at  $+100^{\circ}\text{C}$  for a long time. Please refer to table 3 attached to the sample for selection.

The application temperature range of EPDM is  $-60^{\circ}\text{C}$  to  $+150^{\circ}\text{C}$ . Resistant to dilute acid, alkali and salt corrosion, not resistant to oxidizing acid, aromatics and petroleum products. Please refer to table 4 attached to the sample for selection.

Fluororubber has excellent high temperature resistance and corrosion resistance. Resistant to all kinds of acid, alkali, salt and petroleum products. Please refer to table 5 attached to the sample for selection.

(4) Materials of spring and other structural parts can be selected as follows:

0Cr18Ni12Mo2Ti(G), 0Cr18Ni9(F), 2Cr13 or 3Cr13 (F1), etc.

Chromium steel 2Cr13 or 3Cr13 is used in weak corrosive medium, and stainless steel (0Cr18Ni12Mo2Ti, 0Cr18Ni9) is used in strong corrosive medium.

## Example of Seal Model

MG1	/	35	-	G6	-	B	V	V	G	G	
											Structural material
											Spring material
											Material of auxiliary seal
											Material of stationary ring
											Material of rotating ring
											Types of stationary rings
											Shaft diameter at seal
											Single end universal mechanical seal
											Rubber bellows seal

### Example of Seal Model

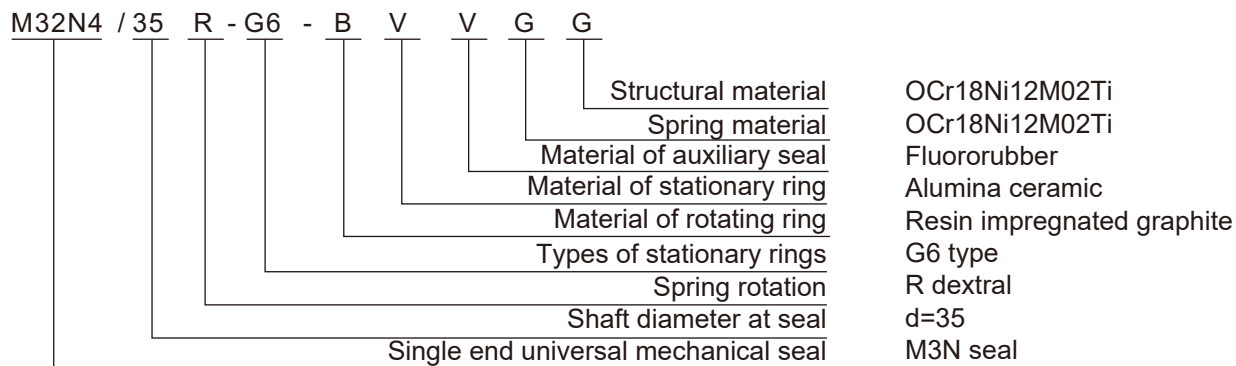

Special notice: In general, the friction pair material of mechanical seal should be a soft hard pair. When the medium contains solid particles, the hard pair should be selected. The material is selected according to the medium.

Structural diagram (see next page)

### Structural Features

1. The segmented design of the pump shaft of this series of pumps fundamentally avoids the damage of corrosion to the motor shaft. The stable and reliable long-term operation of the motor is completely guaranteed.
2. This series of pumps have reliable and novel shaft structure. B35 type standard motor can be used to drive the pump directly for horizontal pumps, and 85 type standard motor can be used to drive the pump directly for vertical pumps.
3. The pump cover and connecting frame are designed as two independent parts with reasonable structure.
4. The structure of this series of pumps is very simple and easy to maintain. Once the pump shaft needs to be replaced, it is easy to disassemble and install, and the positioning is accurate and reliable.
5. This series of pump shaft and motor shaft are rigidly connected. Advanced and reasonable processing and assembly technology make the pump shaft have high concentricity, low vibration and low noise.
6. Compared with the horizontal chemical pump of general structure, the structure of this series of horizontal pumps is more compact, and the floor area of the unit is greatly reduced.
7. This series of pumps adopt excellent hydraulic model design. The pump has stable performance and high efficiency.
8. This series of pump body, pump cover, impeller and other parts are made by investment casting, with high dimensional accuracy, smooth flow channel and beautiful appearance.
9. This series of pump covers, shafts and connecting frames have the greatest versatility.

Structural Diagram(Horizontal)

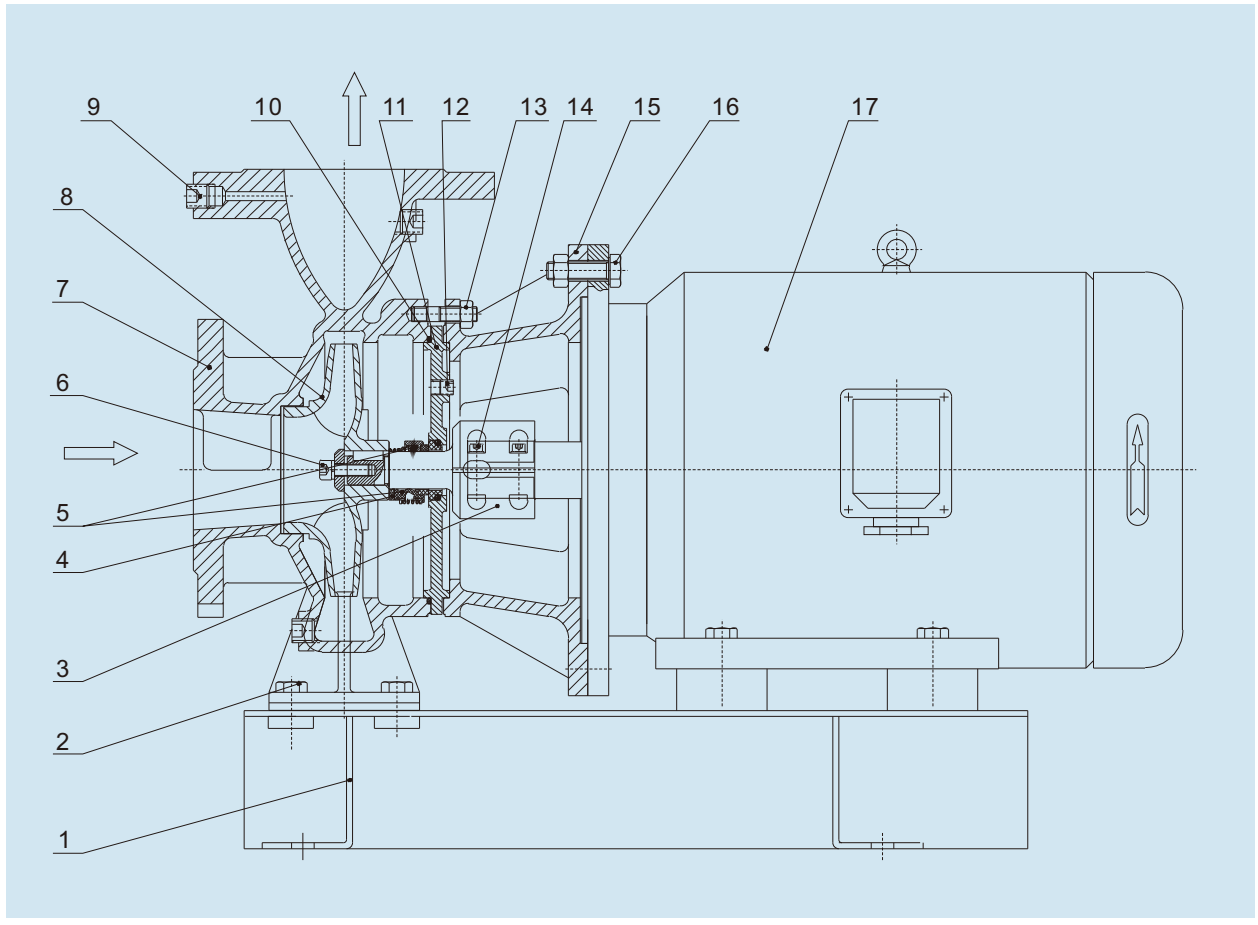

No.	1	2	3	4	5	6	7
Name	Base	Bolt	Shaft	Adjusting sleeve	Mechanical seal	Screw	Casing
Quantity	1	4	1	1(0)	1 Set	1	1

No.	8	9	10	11	12	13	14
Name	Impeller	Bolt 3/8	Seal ring	Pump cover	Bolt 1/8	Bolt	Screw
Quantity	1	Canceled	1	1	Canceled	6(8)	3(2)

No.	15	16	17
Name	Connecting frame	Bolt	Motor
Quantity	1	4(8)	1

Structural Diagram(Vertical)

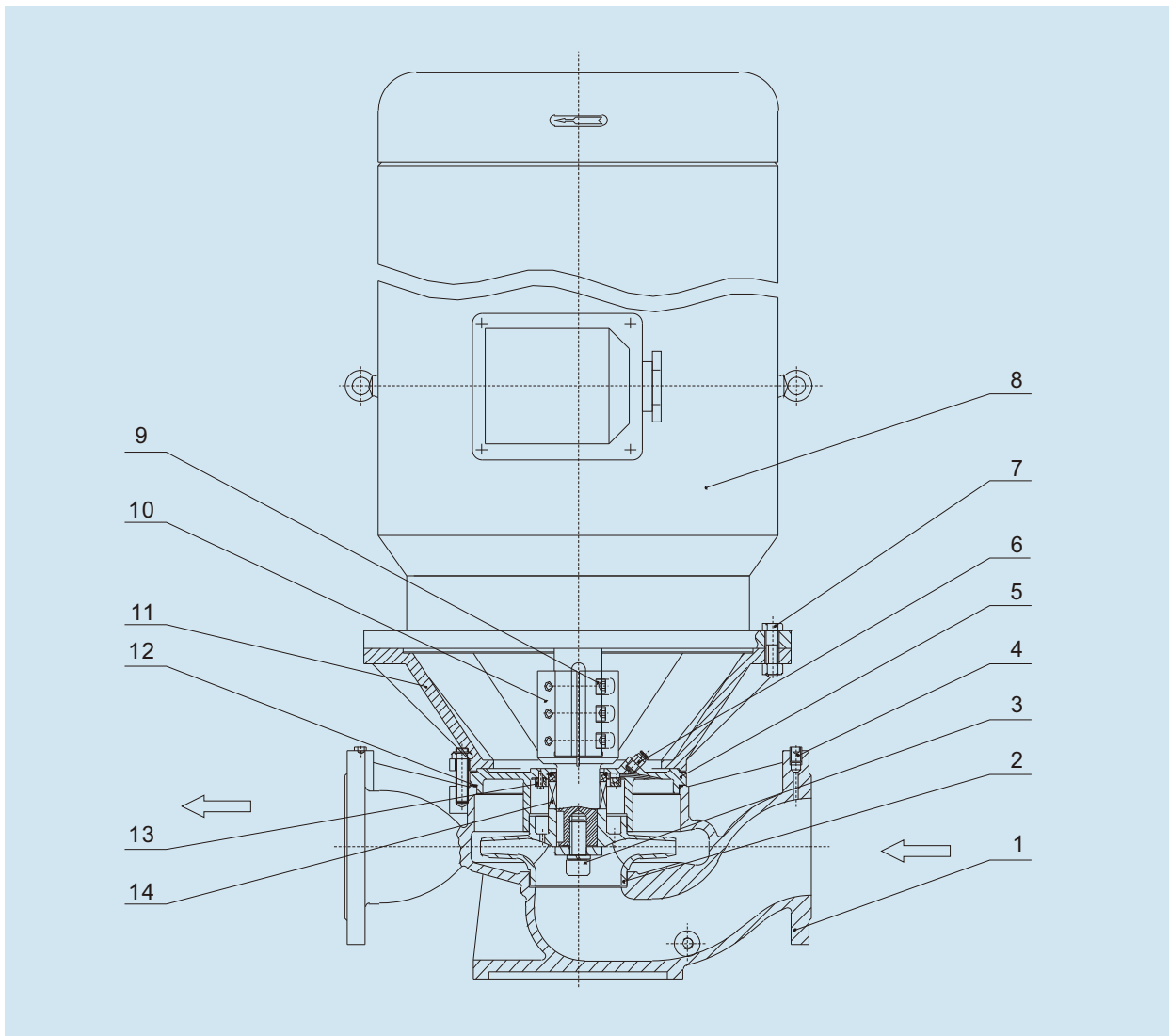

No.	1	2	3	4	5	6	7
Name	Casing	Impeller	Screw	Plug	Pump cover	Vent cock	Bolt
Quantity	1	1	1	Canceled	1	1	4(8)

No.	8	9	10	11	12	13	14
Name	Motor	Screw	Shaft	Connecting frame	Seal ring	Distribution ring	Mechanical seal
Quantity	1	2/3	1	1	1	Canceled	1 set

### Scope of Supply

In order to ensure the long-term reliable operation and normal maintenance of the pump unit, customers can purchase the following spare parts or accessories according to the actual situation (see table below)

Package supply	Spare part	Accessory
Pump unit	Impeller and mechanical seal Pump shaft, O-ring, etc	Connecting plate, foundation bolt, etc
	Supply according to contract	Supply according to contract

### Ordering Instructions

- The performance parameters listed in the sample are only for normal temperature water.
- When transporting non-aqueous media, the user must be clear about the following factors:
  - ① Medium name and composition, temperature and temperature range, concentration and impurity composition;
  - ② Viscosity, medium specific gravity;  
Relevant data show that the viscosity range of centrifugal pump is not more than 150 mm<sup>2</sup>/s。 When the viscosity of the medium is less than or equal to 20 mm<sup>2</sup>/s when the viscosity is greater than or equal to 20mm<sup>2</sup>/s, the pump performance parameters need not be converted.  
The matching motor power listed in the sample is normal temperature clean water as an example. When the specific gravity of medium is different from that of water, the matching power needs to be recalculated.
  - ③ Toxicity, explosiveness and Flammability;
  - ④ Saturated steam pressure or inlet pressure;
  - ⑤ Whether the medium is crystallized or volatilized;

The customer must truly and comprehensively provide the above data or technical requirements, and fill in the technical data of KQWH and KQH chemical pump selection.  
It is convenient for the manufacturer to select materials, seals and matching motors correctly and reasonably, as well as for the customer.  
Further follow-up on the usage.
- As a part of the contract review, the technical data sheet of KQWH and KQH chemical pump type selection has been approved by the relevant departments.  
The copies are filed for future reference, and the copies are sent to the production department together with the order to facilitate the organization of production.
- When there are special requirements for flow rate, head, inlet pressure, motor explosion-proof, etc., it is also necessary to make a special statement.

## Performance Parameter Table

Model	Capacity		Head (m)	Rotation Speed (r/min)	Motor Power (kW)	NPSH <sub>r</sub> (m)	Weight (kg)
	(m <sup>3</sup> /h)	(L/s)					
KQWH KQH 40-100	4.4	1.22	13.2	2960	0.55	2.3	42
	6.3	1.75	12.5				
	7.6	2.11	11.3				
KQWH KQH 40-100A	3.9	1.08	10.6	2960	0.55	2.3	40
	5.6	1.56	10				
	6.7	1.86	9				
KQWH KQH 40-125	4.4	1.22	21	2960	1.1	2.3	46
	6.3	1.75	20				
	7.6	2.11	18				
KQWH KQH 40-125A	3.9	1.08	17.6	2960	0.75	2.3	45
	5.6	1.56	16				
	6.7	1.86	14.4				
KQWH KQH 40-160	4.4	1.22	33	2960	2.2	2.3	56
	6.3	1.75	32				
	7.6	2.11	30				
KQWH KQH 40-160A	4.1	1.14	29	2960	1.5	2.3	52
	5.9	1.64	28				
	7	1.94	26.3				
KQWH KQH 40-160B	3.8	1.06	25.5	2960	1.1	2.3	47
	5.5	1.53	24				
	6.7	1.86	22.5				
KQWH KQH 40-200	4.4	1.22	51	2960	4	2.3	80
	6.3	1.75	50				
	7.6	2.11	48				
KQWH KQH 40-200A	4.1	1.14	45	2960	3	2.3	70
	5.9	1.64	44				
	7	1.94	42				
KQWH KQH 40-200B	3.7	1.03	37	2960	2.2	2.3	60
	5.3	1.47	36				
	6.4	1.78	34.5				
KQWH KQH 40-250	4.4	1.22	82	2960	7.5	2.3	125
	6.3	1.75	80				
	8.3	2.31	74				
KQWH KQH 40-250A	4.1	1.14	72	2960	5.5	2.3	108
	5.9	1.64	70				
	7.8	2.17	65				
KQWH KQH 40-250B	3.8	1.06	61.5	2960	4	2.3	85
	5.5	1.53	60				
	7	1.94	56				
KQWH KQH 50-100	8.8	2.44	13.6	2960	1.1	2.3	36
	12.5	3.47	12.5				
	15	4.17	11.3				
KQWH KQH 50-100A	8	2.22	11	2960	0.75	2.3	35
	11	3.05	10				
	13.2	3.67	9				
KQWH KQH 50-125	8.8	2.44	21.5	2960	1.5	2.3	43
	12.5	3.47	20				
	15	4.17	17.8				
KQWH KQH 50-125A	8	2.22	17	2960	1.1	2.3	38
	11	3.05	16				
	13.2	3.67	14				
KQWH KQH 50-160	8.8	2.44	33	2960	3	2.3	59
	12.5	3.47	32				
	15	4.17	30				
KQWH KQH 50-160A	8.2	2.28	29	2960	2.2	2.3	51
	11.7	3.25	28				
	14	3.90	26				
KQWH KQH 50-160B	7.3	2.03	23	2960	1.5	2.3	47
	10.4	2.89	22				
	12.5	3.47	20				
KQWH KQH 50-200	8.8	2.44	52	2960	5.5	2.3	100
	12.5	3.47	50				
	15	4.17	48				
KQWH KQH 50-200A	8.3	2.31	45.8	2960	4	2.3	75
	11.7	3.25	44				
	14	3.9	42				
KQWH KQH 50-200B	7.3	2.03	37	2960	3	2.3	65
	10.4	2.89	36				
	12.5	3.47	34				
KQWH KQH 50-250	8.8	2.44	82	2960	11	2.3	170
	12.5	3.47	80				
	16.3	4.53	77.5				
KQWH KQH 50-250A	8.2	2.28	71.5	2960	7.5	2.3	126
	11.6	3.22	70				
	15.2	4.22	68				

Model	Capacity		Head (m)	Rotation Speed (r/min)	Motor Power (kW)	NPSH <sub>r</sub> (m)	Weight (kg)
	(m <sup>3</sup> /h)	(L/s)					
KQWH KQH 50-250B	7.6	2.11	61.4	2960	7.5	2.3	125
	10.8	3	60				
	14	3.89	58				
KQWH KQH 65-100	17.5	4.86	13.7	2960	1.5	2.5	49
	25	6.94	12.5				
	30	8.33	10.5				
KQWH KQH 65-100A	15.6	4.30	21	2960	1.1	2.5	45
	22.3	6.19	10				
	27	7.50	8.4				
KQWH KQH 65-125	17.5	4.86	21.5	2960	3	2.5	64
	25	6.94	20				
	30	8.33	18				
KQWH KQH 65-125A	15.6	4.30	17	2960	2.2	2.5	54
	22.3	6.19	16				
	27	7.50	14.4				
KQWH KQH 65-160	17.5	4.86	34.3	2960	4	2.5	75
	25	6.94	32				
	30	8.33	27.5				
KQWH KQH 65-160A	16.4	4.56	30	2960	4	2.5	75
	23.4	6.50	28				
	28	7.78	24				
KQWH KQH 65-160B	15	4.17	26	2960	3	2.5	64
	21.6	6.00	24				
	26	7.20	20.6				
KQWH KQH 65-200	17.5	4.86	52.7	2960	7.5	2.5	107
	25	6.94	50				
	30	8.33	45.5				
KQWH KQH 65-200A	16.4	4.56	46.4	2960	7.5	2.5	107
	23.4	6.50	44				
	28	7.78	40				
KQWH KQH 65-200B	15.2	4.22	40	2960	5.5	2.5	100
	21.8	6.06	38				
	26.2	7.27	34.5				
KQWH KQH 65-250	17.5	4.86	82	2960	15	2.5	180
	25	6.94	80				
	30	8.33	76.5				
KQWH KQH 65-250A	16.4	4.56	71.5	2960	11	2.5	170
	23.4	6.50	70				
	28	7.78	67				
KQWH KQH 65-250B	15	4.17	61.5	2960	11	2.5	170
	21.6	6.00	60				
	26	7.22	57.4				
KQWH KQH 65-315	17.5	4.86	127	2960	30	2.5	330
	25	6.94	125				
	32.5	9.03	122				
KQWH KQH 65-315A	16.6	4.61	115	2960	22	2.5	265
	23.7	6.58	113				
	31	8.60	110				
KQWH KQH 65-315B	15.7	4.36	103	2960	18.5	2.5	225
	22.5	6.25	101				
	29.2	8.00	98				
KQWH KQH 65-315C	14.4	4.00	86	2960	15	2.5	215
	20.6	5.72	85				
	26.8	7.44	83				
KQWH KQH 80-100	35	9.72	13.8	2960	3	3	63
	50	13.90	12.5				
	60	16.70	10				
KQWH KQH 80-100A	31.3	8.70	11	2960	2.2	3	54
	44.7	12.50	10				
	53.6	14.90	8				
KQWH KQH 80-125	35	9.72	22	2960	5.5	3	105
	50	13.9	20				
	60	16.7	17				
KQWH KQH 80-125A	31.3	8.70	17.5	2960	4	3	79
	45	12.50	16				
	54	15.00	13.6				
KQWH KQH 80-160	35	9.72	35	2960	7.5	3	112
	50	13.9	32				
	60	16.7	28				
KQWH KQH 80-160A	32.7	9.1	30.6	2960	7.5	3	112
	46.7	13	28				
	56	15.6	24				
KQWH KQH 80-160B	30.3	8.4	26	2960	5.5	3	105
	43.3	12	24				
	52	14.4	21				

Performance Parameter Table

Model	Capacity		Head (m)	Rotation Speed (r/min)	Motor Power (kW)	NPSH <sub>r</sub> (m)	Weight (kg)
	(m <sup>3</sup> /h)	(L/s)					
KQWH KQH 80-200	35	9.72	53.5	2960	15	3	175
	50	13.90	50				
	60	16.70	46				
KQWH KQH 80-200A	32.8	9.10	47	2960	11	3	165
	47	13.10	44				
	56.4	15.70	40				
KQWH KQH 80-200B	30.5	8.50	40.6	2960	7.5	3	115
	43.5	12.10	38				
	52	14.40	33.4				
KQWH KQH 80-250	35	9.72	83	2960	22	3	235
	50	13.90	80				
	60	16.70	72				
KQWH KQH 80-250A	32.5	9.00	73	2960	18.5	3	203
	46.7	13.00	70				
	56	15.60	63				
KQWH KQH 80-250B	30	8.30	62	2960	15	3	175
	43.3	12.00	60				
	52	14.40	54				
KQWH KQH 80-315	35	9.72	129	2960	37	3	355
	50	13.90	125				
	60	16.70	118				
KQWH KQH 80-315A	32.5	9.00	117	2960	30	3	340
	46.7	13.00	113				
	56	15.60	106				
KQWH KQH 80-315B	30	8.30	105	2960	30	3	340
	43.3	12.00	101				
	52	14.40	94				
KQWH KQH 80-315C	28	7.78	88	2960	22	3	275
	40	11.10	85				
	48	13.30	78				
KQWH KQH 100-100	70	19.40	13.6	2960	5.5	4.5	113
	100	27.80	12.5				
	120	33.30	11				
KQWH KQH 100-100A	62.6	17.40	11	2960	4	4.5	91
	89	24.70	10				
	107	29.70	8.8				
KQWH KQH 100-125	70	19.40	23.5	2960	11	4.5	177
	100	27.80	20				
	120	33.30	14				
KQWH KQH 100-125A	62.6	17.40	19	2960	7.5	4.5	132
	89	24.70	16				
	107	29.70	11				
KQWH KQH 100-160	70	19.40	36.5	2960	15	4.5	188
	100	27.80	32				
	120	33.30	24				
KQWH KQH 100-160A	65.4	18.20	32	2960	11	4.5	178
	93.5	26.00	28				
	112	31.10	21				
KQWH KQH 100-160B	60.6	16.80	27	2960	11	4.5	177
	86.6	24.10	24				
	104	28.90	18				
KQWH KQH 100-200	70	19.40	54	2960	22	4	250
	100	27.80	50				
	120	33.30	42				
KQWH KQH 100-200A	65.4	18.20	47.5	2960	18.5	4	218
	93.5	26.00	44				
	112	31.10	37				
KQWH KQH 100-200B	61	16.90	41	2960	15	4	189
	87	24.20	38				
	104	28.90	32				
KQWH KQH 100-250	70	19.4	87	2960	37	4	345
	100	27.8	80				
	120	33.3	68				
KQWH KQH 100-250A	65.4	18.2	76	2960	30	4	330
	93.5	26	70				
	112	31.1	59				
KQWH KQH 100-250B	61	16.90	65	2960	30	4	330
	87	24.20	60				
	104	28.90	50				
KQWH KQH 100-315	70	19.40	129	2960	75	4	690
	100	27.80	125				
	120	33.30	118				
KQWH KQH 100-315A	66	18.30	117	2960	55	4	550
	95	26.40	113				
	114	31.70	106				

Model	Capacity		Head (m)	Rotation Speed (r/min)	Motor Power (kW)	NPSH <sub>r</sub> (m)	Weight (kg)
	(m <sup>3</sup> /h)	(L/s)					
KQWH KQH 100-315B	63	17.50	105	2960	45	4	440
	90	25.00	101				
	108	30.00	94				
KQWH KQH 100-315C	58	16.1	88	2960	37	4	440
	82	22.8	85				
	98.5	27.3	78				
KQWH KQH 100-125(I)	60	16.67	6.5	1480	2.2	3	100
	100	27.80	5				
	120	33.33	4				
KQWH KQH 100-160(I)	60	16.67	10	1480	4	3	120
	100	27.80	8				
	120	33.33	7				
KQWH KQH 100-160(IA)	52	14.50	7.3	1480	3	3	109
	87	24.20	6.3				
	104	28.90	5.4				
KQWH KQH 100-200(I)	60	16.67	14	1480	5.5	3	145
	100	27.80	12.5				
	120	33.33	11				
KQWH KQH 100-200(IA)	51.7	14.36	10.8	1480	4	3	120
	86	23.92	9.3				
	103	28.61	8.2				
KQWH KQH 100-250(I)	60	16.70	21.5	1480	11	3	212
	100	27.80	20				
	120	33.30	18.5				
KQWH KQH 100-250(IA)	56	15.60	18.7	1480	7.5	3	163
	93	25.80	17.4				
	112	31.10	16				
KQWH KQH 100-250(IA)B	52	14.50	16	1480	5.5	3	155
	87	24.20	15				
	104	28.90	14				
KQWH KQH 100-315(I)	60	16.70	33.5	1480	15	3	228
	100	27.80	32				
	120	33.30	30.5				
KQWH KQH 100-315(IA)	55	15.30	28	1480	11	3	214
	91	25.30	27				
	110	30.60	25.7				
KQWH KQH 100-315(IA)B	47	13.10	21	1480	7.5	3	165
	79	21.90	20				
	95	26.40	19				
KQWH KQH 100-400(I)	60	16.70	52	1480	30	3	375
	100	27.80	50				
	120	33.30	48.5				
KQWH KQH 100-400(IA)	56.4	15.70	46	1480	22	3	295
	94	26.10	44				
	113	31.40	43				
KQWH KQH 100-400(IA)B	52.3	14.50	39	1480	18.5	3	247
	87	24.20	38				
	105	29.20	37				
KQWH KQH 100-400(IA)C	48.6	13.50	34	1480	15	3	239
	81	22.60	32.8				
	97	26.90	32				
KQWH KQH 125-100	96	26.70	13	2960	11	4	180
	160	44.40	12.5				
	192	53.30	12				
KQWH KQH 125-100A	86	23.90	10.4	2960	7.5	4	125
	143	39.70	10				
	172	47.80	9.6				
KQWH KQH 125-125	96	26.70	22.6	2960	15	4	191
	160	44.40	20				
	192	53.30	17				
KQWH KQH 125-125A	86	23.90	18	2960	11	4	180
	143	39.70	16				
	172	47.80	13.6				
KQWH KQH 125-160	96	26.7	36	2960	22	4	255
	160	44.4	32				
	192	53.3	28				
KQWH KQH 125-160A	90	25	31.5	2960	18.5	4	210
	150	41.7	28				
	180	50	24.5				
KQWH KQH 125-160B	83	21.7	27.5	2960	15	4	191
	138	38.3	24				
	166	46.1	21				
KQWH KQH 125-200	96	26.70	55	2960	37	5.5	330
	160	44.40	50				
	192	53.30	46				

## Performance Parameter Table

Model	Capacity		Head (m)	Rotation Speed (r/min)	Motor Power (kW)	NPSH <sub>r</sub> (m)	Weight (kg)
	(m <sup>3</sup> /h)	(L/s)					
KQWH KQH 125-200A	90	25.00	48.4	2960	30	5.5	315
	150	41.70	44				
	180	50.00	40.5				
KQWH KQH 125-200B	83	21.7	41.3	2960	22	5.5	255
	138	38.3	37.5				
	166	46.1	34.5				
KQWH KQH 125-250	96	26.70	87	2960	55	5	500
	160	44.40	80				
	192	53.30	73				
KQWH KQH 125-250A	90	25.00	76	2960	45	5	395
	150	41.70	70				
	180	50.00	64				
KQWH KQH 125-250B	83	21.70	65	2960	37	5	340
	138	38.30	60				
	166	46.10	55				
KQWH KQH 125-315	96	26.70	129	2960	90	5	790
	160	44.40	125				
	192	53.30	118				
KQWH KQH 125-315A	90	25.00	115	2960	75	5	706
	150	41.70	110				
	180	50.00	105				
KQWH KQH 125-315B	86	23.90	105	2960	75	5	705
	143	39.70	100				
	172	47.80	94				
KQWH KQH 125-315C	80.5	22.40	96	2960	55	5	580
	134	37.20	88				
	161	44.70	81				
KQWH KQH 150-200	140	38.90	13.8	1480	15	3	276
	200	55.60	12.5				
	240	66.70	10.6				
KQWH KQH 150-200A	125	34.70	11	1480	11	3	260
	179	49.70	10				
	215	59.70	8.5				
KQWH KQH 150-250	140	38.90	21.8	1480	18.5	3	315
	200	55.60	20				
	240	66.70	17				
KQWH KQH 150-250A	129	35.80	18.5	1480	15	3	278
	184	51.10	17				
	221	61.40	14.4				
KQWH KQH 150-250B	117	32.50	15.2	1480	11	3	261
	167	46.40	14				
	200	55.60	12				
KQWH KQH 150-315	140	38.90	33.8	1480	30	3.5	420
	200	55.60	32				
	240	66.70	28				
KQWH KQH 150-315A	131	36.40	29.5	1480	22	3.5	350
	187	51.90	28				
	225	62.50	24.5				
KQWH KQH 150-315B	121	33.60	25.8	1480	18.5	3.5	330
	173	48.10	24				
	208	57.80	20.7				
KQWH KQH 150-400	140	38.90	53	1480	45	3.5	490
	200	55.60	50				
	240	66.70	44				
KQWH KQH 150-400A	131	36.40	46.6	1480	37	3.5	440
	187	51.90	44				
	225	62.50	38.3				
KQWH KQH 150-400B	122	33.90	40	1480	30	3.5	423
	174	48.30	38				
	209	58.10	33				
KQWH KQH 150-400C	112	31.10	34	1480	22	3.5	352
	160	44.40	32				
	192	53.30	28				
KQWH KQH 200-200(I)	280	77.778	13.4	1480	22	4	402
	400	111.11	12.5				
	480	133.33	10.5				
KQWH KQH 200-200(I)A	250	69.444	10.7	1480	18.5	4	380
	358	99.444	10				
	430	119.44	8.5				
KQWH KQH 200-250(I)	280	77.78	22.2	1480	30	4	475
	400	111.11	20				
	480	133.33	14				
KQWH KQH 200-250(I)A	250	69.444	18	1480	22	4	402
	358	99.444	16				
	430	119.44	11.2				

Model	Capacity		Head (m)	Rotation Speed (r/min)	Motor Power (kW)	NPSH <sub>r</sub> (m)	Weight (kg)
	(m <sup>3</sup> /h)	(L/s)					
KQWH KQH 200-250(I)B	226	62.778	14.6	1480	18.5	4	380
	322	89.444	13				
	386	107.222	9				
KQWH KQH 200-315(I)	280	77.78	36	1480	55	4	708
	400	111.11	32				
	480	133.33	26				
KQWH KQH 200-315(I)A	262	72.78	31.5	1480	45	4	600
	374	103.89	28				
	449	124.72	23				
KQWH KQH 200-315(I)B	242	67.22	27	1480	37	4	560
	346	96.10	24				
	415	115.28	19.5				
KQWH KQH 200-400(I)	280	77.78	54.5	1480	75	4	850
	400	111.11	50				
	480	133.33	39				
KQWH KQH 200-400(I)A	262	72.78	48	1480	75	4	850
	374	103.89	44				
	449	124.72	34				
KQWH KQH 200-400(I)B	242	67.22	41.4	1480	55	4	708
	346	96.10	38				
	415	115.28	29.6				
KQWH KQH 200-400(I)C	224	62.22	34.9	1480	45	4	600
	320	88.89	32				
	384	106.67	25				

Model	Capacity		Head (m)	Rotation Speed (r/min)	Motor Power (kW)	NPSH <sub>r</sub> (m)	Weight (kg)
	(m <sup>3</sup> /h)	(L/s)					
KQWHD KQHD 40-100	2.2	0.61	3.3	1480	0.55	2.5	17
	3.2	0.89	3				
	3.9	1.10	2.8				
KQWHD KQHD 40-125	2.2	0.61	5.5	1480	0.55	2.5	23
	3.2	0.89	5				
	3.9	1.10	4.5				
KQWHD KQHD 40-125A	2	0.56	4.4	1480	0.55	2.5	19
	2.8	0.78	4				
	3.4	0.94	3.6				
KQWHD KQHD 40-160	2.2	0.61	8.5	1480	0.55	2.5	25
	3.2	0.89	8				
	3.9	1.10	7.5				
KQWHD KQHD 40-160A	2	0.56	6.8	1480	0.55	2.5	23
	2.8	0.78	6.4				
	3.4	0.94	6				
KQWHD KQHD 40-200	2.2	0.61	13	1480	0.55	2.5	40
	3.2	0.89	12.5				
	3.9	1.10	12				
KQWHD KQHD 40-200A	2	0.56	10.4	1480	0.55	2.5	38
	2.8	0.78	10				
	3.4	0.94	9.6				
KQWHD KQHD 40-250	2.2	0.61	20.5	1480	1.1	2.5	60
	3.2	0.89	20				
	4.2	1.17	18.5				
KQWHD KQHD 40-250A	2	0.56	16.4	1480	0.75	2.5	55
	2.8	0.78	16				
	3.7	1.03	15				

Performance Parameter Table

Model	Capacity		Head (m)	Rotation Speed (r/min)	Motor Power (kW)	NPSH <sub>r</sub> (m)	Weight (kg)
	(m <sup>3</sup> /h)	(L/s)					
KQWHD KQHD 40-250B	1.6	0.44	13.2	1480	0.55	2.5	48
	2.3	0.64	13				
	3.4	0.94	12				
KQWHD KQHD 50-100	3.8	1.06	3.4	1480	0.55	2.5	19
	6.3	1.75	3				
	7.5	2.08	2.8				
KQWHD KQHD 50-125	3.8	1.06	5.4	1480	0.55	2.5	30
	6.3	1.75	5				
	7.5	2.08	4.6				
KQWHD KQHD 50-125A	3.4	0.94	4.3	1480	0.55	2.5	19
	5.6	1.56	4				
	6.7	1.86	3.7				
KQWHD KQHD 50-160	3.8	1.06	8.5	1480	0.55	2.5	40
	6.3	1.75	8				
	7.5	2.08	7.5				
KQWHD KQHD 50-160A	3	0.83	5.6	1480	0.55	2.5	30
	5.1	1.42	5.3				
	6.1	1.67	4.9				
KQWHD KQHD 50-200	3.8	1.06	13.1	1480	0.75	2.5	50
	6.3	1.75	12.5				
	7.5	2.08	12				
KQWHD KQHD 50-200A	3.3	0.92	10	1480	0.55	2.5	50
	5.5	1.53	9.5				
	6.6	1.83	9				
KQWHD KQHD 50-250	3.8	1.06	20.5	1480	1.5	2.5	66
	6.3	1.75	20				
	7.5	2.08	19.5				
KQWHD KQHD 50-250A	3.4	0.94	16.4	1480	1.1	2.5	59
	5.6	1.56	16				
	6.7	1.86	15.6				
KQWHD KQHD 50-250B	3.1	0.86	13.2	1480	0.75	2.5	55
	5.1	1.42	13				
	6.1	1.69	12.5				
KQWHD KQHD 65-100	7.5	2.08	3.5	1480	0.55	2.8	29
	12.5	3.47	3				
	15	4.17	2.5				
KQWHD KQHD 65-125	7.5	2.08	5.4	1480	0.55	2.8	35
	12.5	3.47	5				
	15	4.17	4.7				
KQWHD KQHD 65-125A	6.6	1.83	4.1	1480	0.55	2.8	27
	11	3.06	3.8				
	13.2	3.67	3.6				
KQWHD KQHD 65-160	7.5	2.08	8.8	1480	0.55	2.8	46
	12.5	3.47	8				
	15	4.17	7.2				
KQWHD KQHD 65-160A	6.5	1.81	6.6	1480	0.55	2.8	35
	10.8	3.00	6				
	13	3.61	5.4				
KQWHD KQHD 65-200	7.5	2.08	13.2	1480	1.1	2.8	52
	12.5	3.47	12.5				
	15	4.17	11.8				
KQWHD KQHD 65-200A	6.8	1.89	10.7	1480	0.75	2.8	48
	11.3	3.14	10.1				
	13.5	3.75	9.6				
KQWHD KQHD 65-250	7.5	2.08	21	1480	2.2	2.8	74
	12.5	3.47	20				
	15	4.17	19.4				
KQWHD KQHD 65-250A	7	1.94	18.4	1480	1.5	2.8	70
	11.7	3.25	17.6				
	14.1	3.92	17				
KQWHD KQHD 65-250B	6.1	1.69	14.1	1480	1.1	2.8	65
	10.2	2.83	13.4				
	12.3	3.42	12.7				
KQWH KQH 65-315	7.5	2.08	32.3	1480	4	2.8	97
	12.5	3.47	32				
	15	4.17	31.7				
KQWH KQH 65-315A	7	1.94	28.1	1480	3	2.8	92
	11.7	3.25	28				
	14	3.92	27.6				
KQWH KQH 65-315B	6.1	1.69	21.1	1480	3	2.8	90
	10.1	2.81	21				
	12.1	3.36	20.8				
KQWHD KQHD 80-100	15	4.17	3.5	1480	0.55	2.8	33
	25	6.94	3				
	30	8.33	2.5				

Model	Capacity		Head (m)	Rotation Speed (r/min)	Motor Power (kW)	NPSH <sub>r</sub> (m)	Weight (kg)
	(m <sup>3</sup> /h)	(L/s)					
KQWHD KQHD 80-125	15	4.17	5.6	1480	0.75	2.8	52
	25	6.94	5				
	30	8.33	4.5				
KQWHD KQHD 80-125A	13.1	3.05	4.3	1480	0.55	2.8	48
	21.8	6.05	3.8				
	26.2	7.28	3.4				
KQWHD KQHD 80-160	15	4.17	9	1480	1.1	2.8	53
	25	6.94	8				
	30	8.33	7.2				
KQWHD KQHD 80-160A	13	3.61	6.7	1480	0.75	2.8	52
	21.6	6.00	6				
	25.9	7.19	5.4				
KQWHD KQHD 80-200	15	4.17	13.2	1480	2.2	2.8	61
	25	6.94	12.5				
	30	8.33	11.8				
KQWHD KQHD 80-200A	14	3.89	11.5	1480	1.5	2.8	57
	23.3	6.47	10.9				
	27.9	7.75	10.2				
KQWHD KQHD 80-250	15	4.17	21	1480	3	2.8	78
	25	6.94	20				
	30	8.33	18.8				
KQWHD KQHD 80-250A	13.3	3.69	16.6	1480	2.2	2.8	68
	22.2	6.17	15.8				
	26.6	7.39	14.8				
KQWHD KQHD 80-250B	11.9	3.31	13.5	1480	1.5	2.8	63
	19.8	5.50	12.6				
	23.8	6.61	11.8				
KQWHD KQHD 80-315	15	4.17	32.5	1480	5.5	2.8	130
	25	6.94	32				
	30	8.33	31.5				
KQWHD KQHD 80-315A	14	3.89	28.3	1480	4	2.8	102
	23	6.39	27.9				
	28	7.78	27.4				
KQWHD KQHD 80-315B	12.1	3.36	21.3	1480	3	2.8	97
	20.2	5.61	21				
	24.3	6.75	20.6				
KQWHD KQHD 100-100	30	8.33	3.5	1480	0.75	3	62
	50	13.89	3				
	60	16.67	2.5				
KQWHD KQHD 100-125	30	8.33	6	1480	1.1	3	71
	50	13.89	5				
	60	16.67	4				
KQWHD KQHD 100-125A	26.8	7.44	4.8	1480	1.1	3	68
	44.6	12.40	4				
	53.5	14.90	3.2				
KQWHD KQHD 100-160	30	8.33	9.2	1480	2.2	3	80
	50	13.89	8				
	60	16.67	6.8				
KQWHD KQHD 100-160A	26.8	7.44	7.3	1480	1.5	3	75
	44.6	12.40	6.3				
	53.5	14.90	5.4				
KQWHD KQHD 100-200	30	8.33	13.5	1480	3	3	90
	50	13.89	12.5				
	60	16.67	11.8				
KQWHD KQHD 100-200A	26.8	7.44	10.7	1480	2.2	3	80
	44.6	12.40	9.9				
	53.5	14.90	9.4				
KQWHD KQHD 100-250	30	8.33	21.3	1480	5.5	3	140
	50	13.89	20				
	60	16.67	19				
KQWHD KQHD 100-250A	28	7.78	18.6	1480	4	3	115
	46.7	12.97	17.4				
	56	15.56	16.6				
KQWHD KQHD 100-250B	24.2	6.72	14	1480	3	3	105
	40.4	11.22	13				
	48.5	13.47	12.4				
KQWHD KQHD 100-315	30	8.33	34	1480	11	3	223
	50	13.89	32				
	60	16.67	30				
KQWHD KQHD 100-315A	28	7.78	29.6	1480	7.5	3	176
	46.7	12.97	27.9				
	56	15.56	26.1				
KQWHD KQHD 100-315B	24.2	6.72	22.3	1480	5.5	3	163
	40.4	11.22	21				
	48.5	13.47	19.1				

## Characteristic Curve Graph

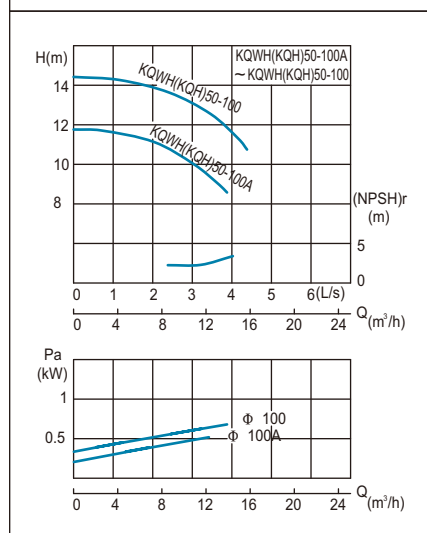
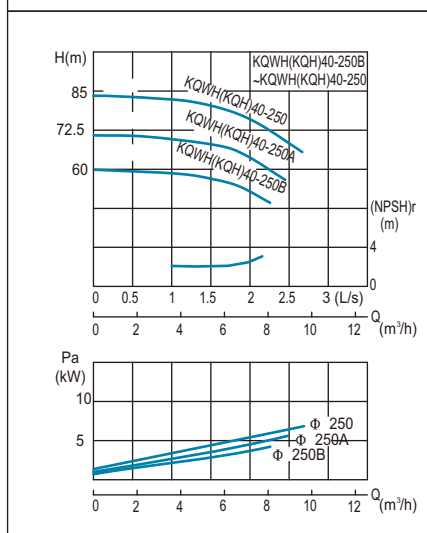
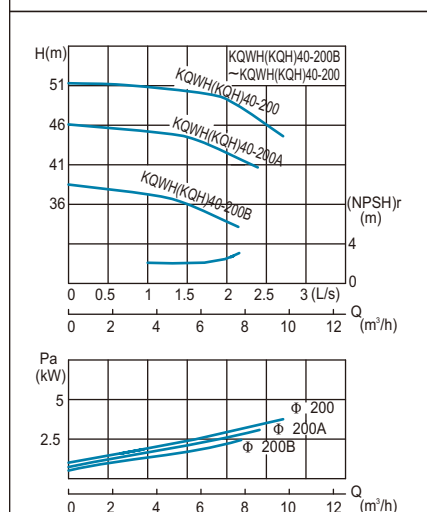
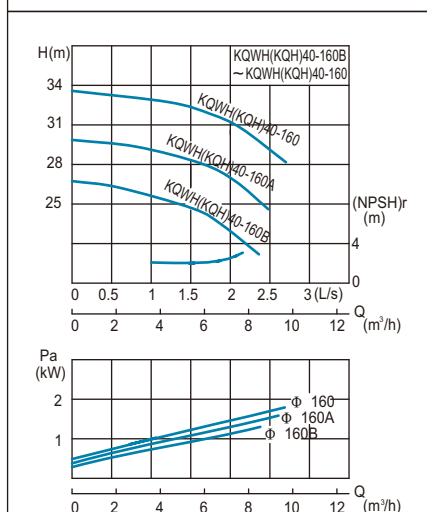
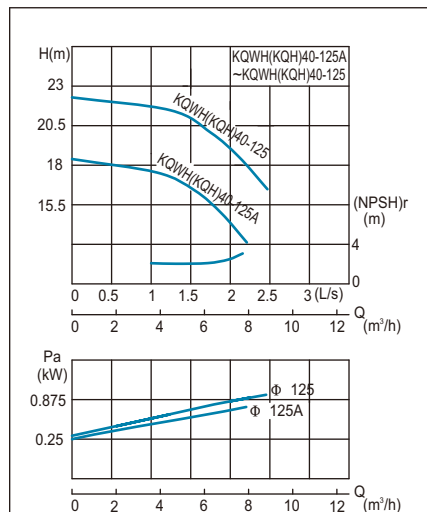
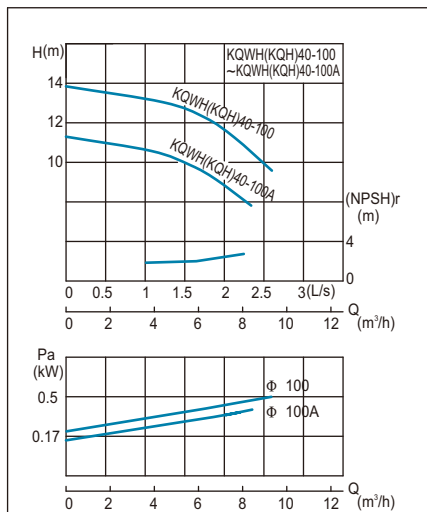

Characteristic Curve Graph

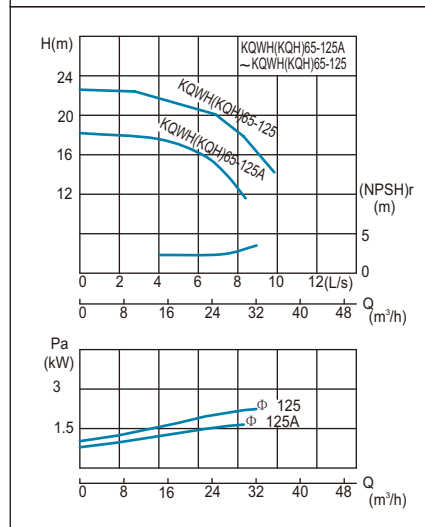
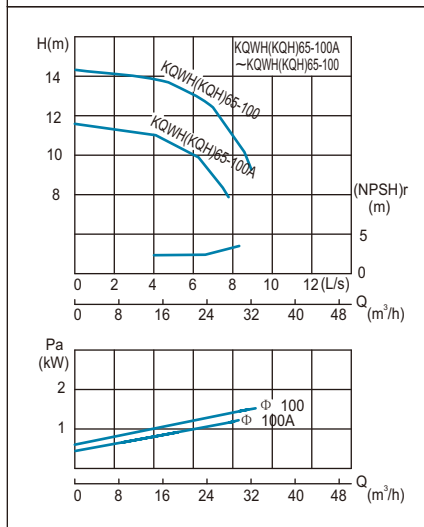
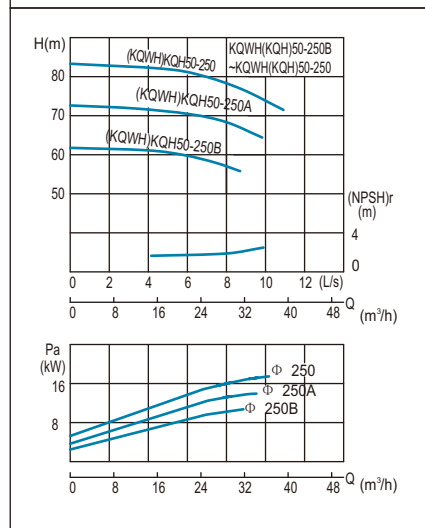
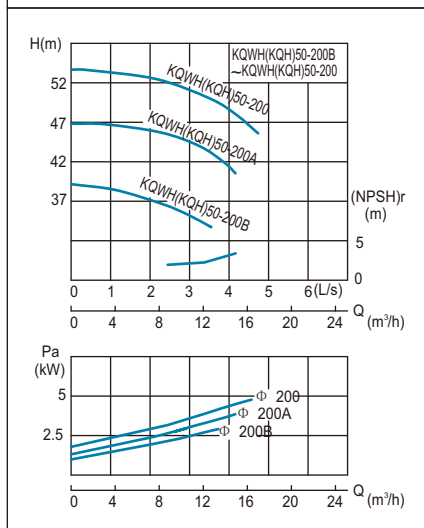
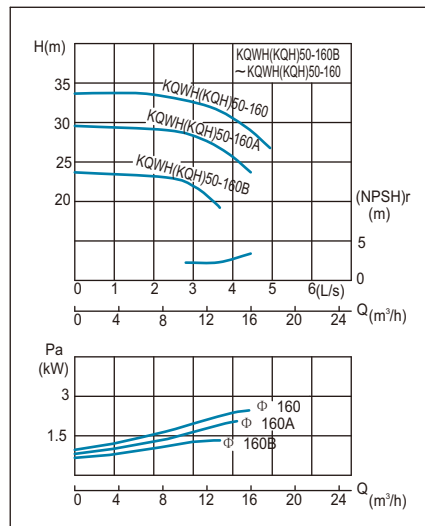
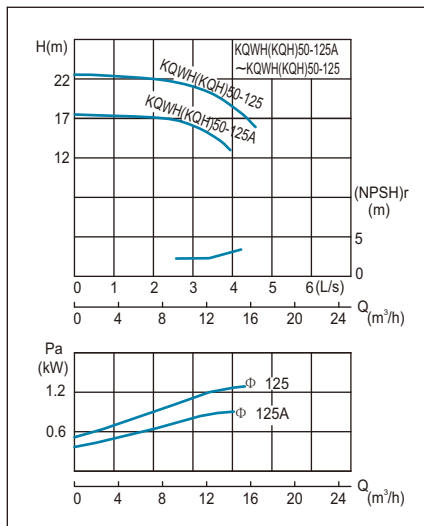

## Characteristic Curve Graph

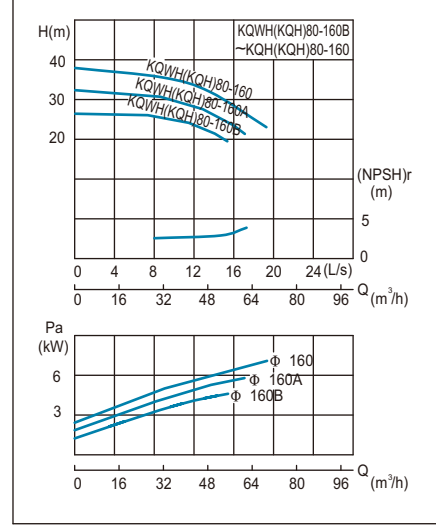
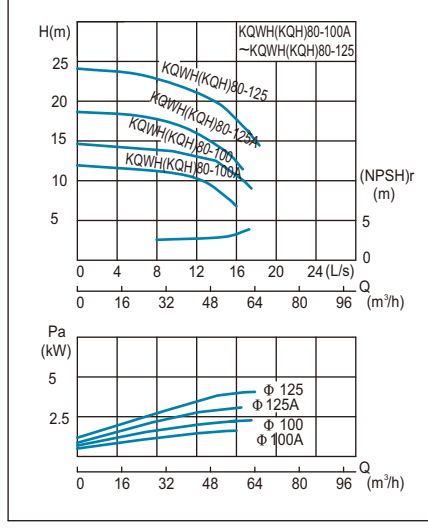
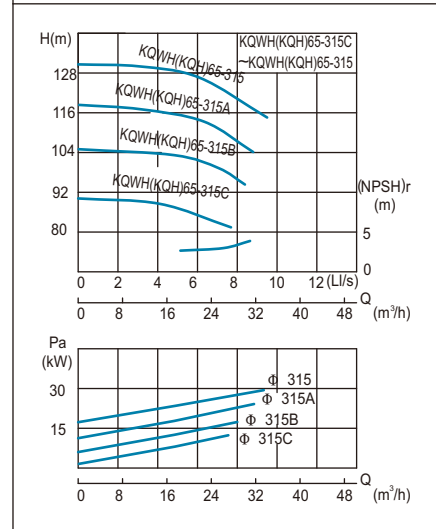
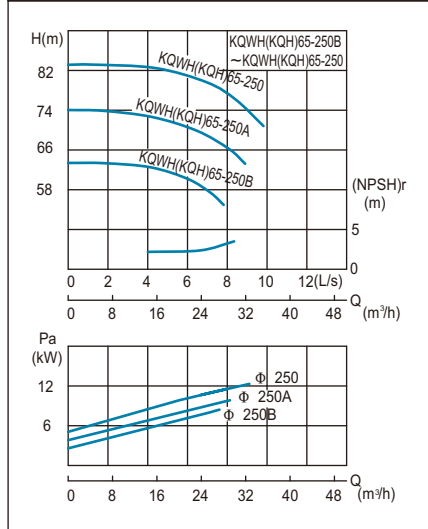
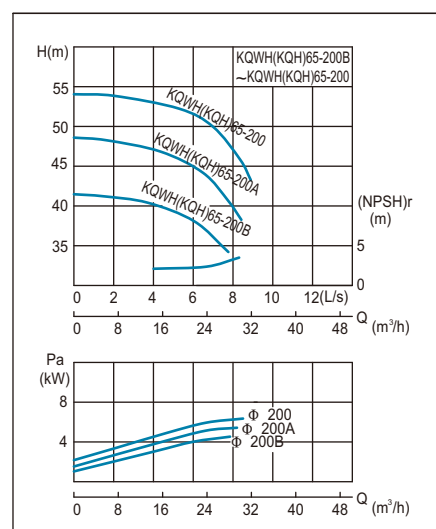
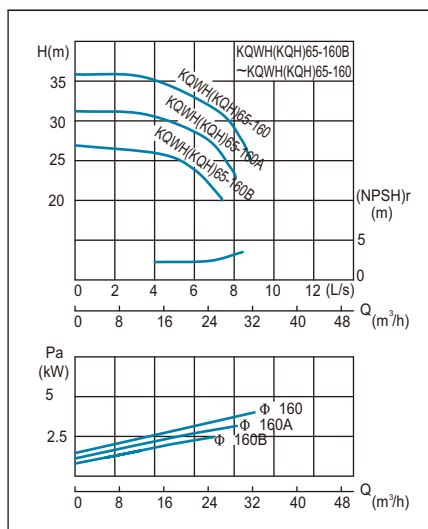

Characteristic Curve Graph

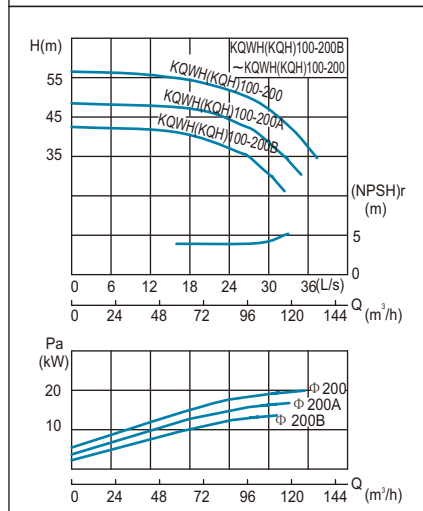
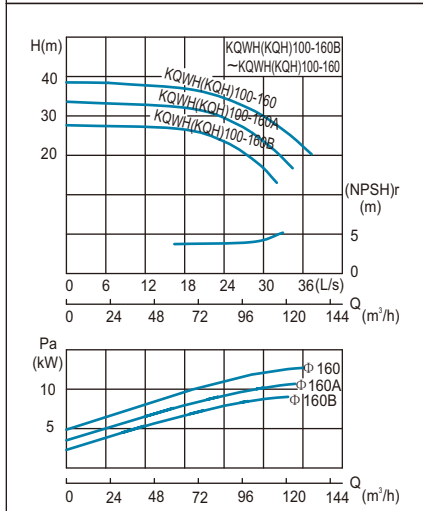
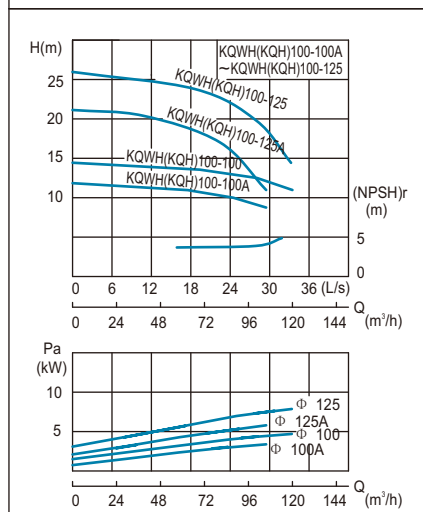
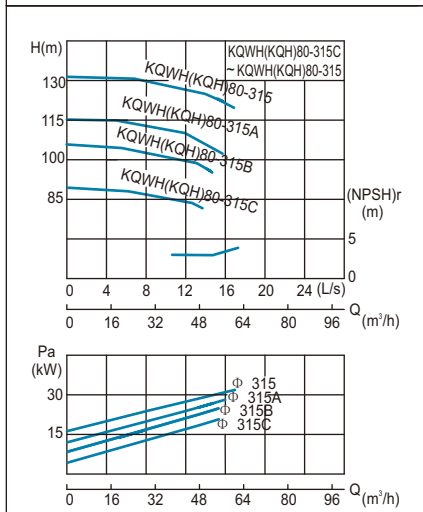
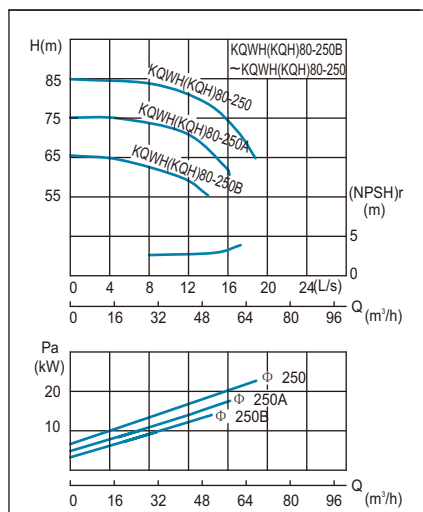
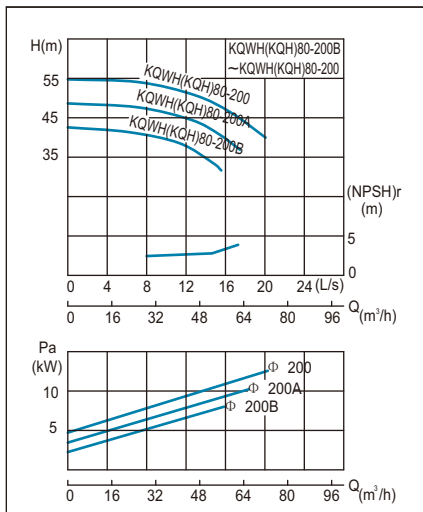

## Characteristic Curve Graph

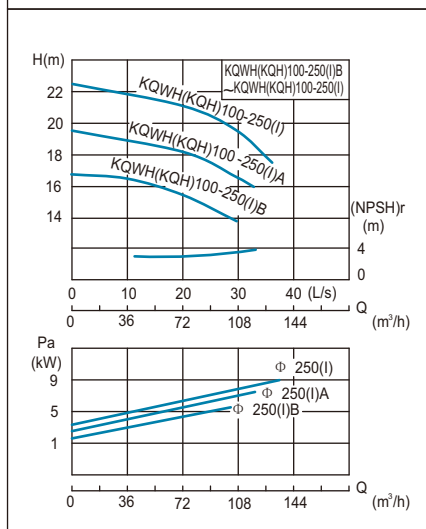
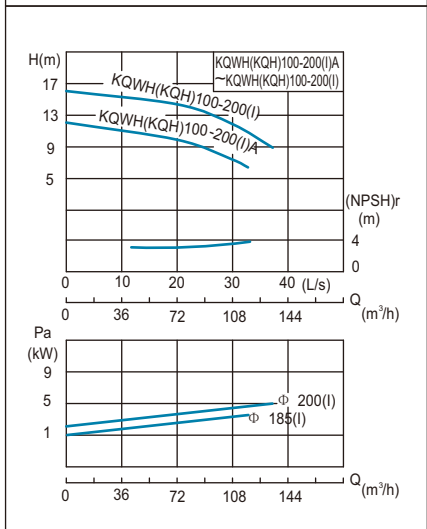
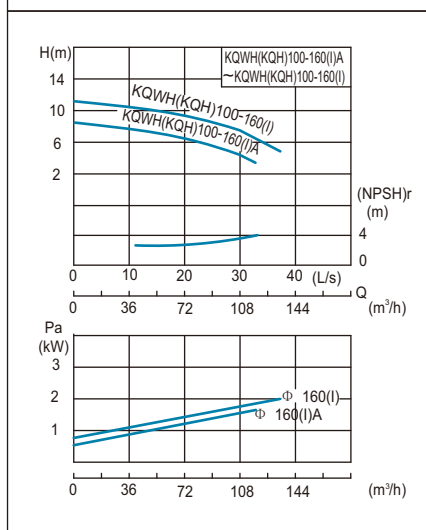
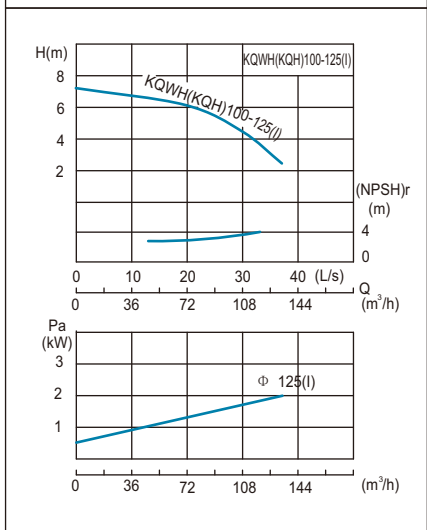
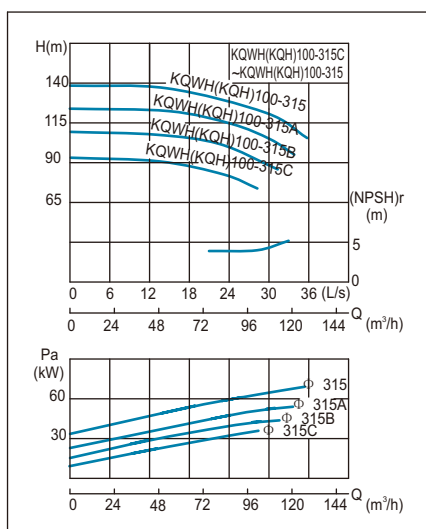
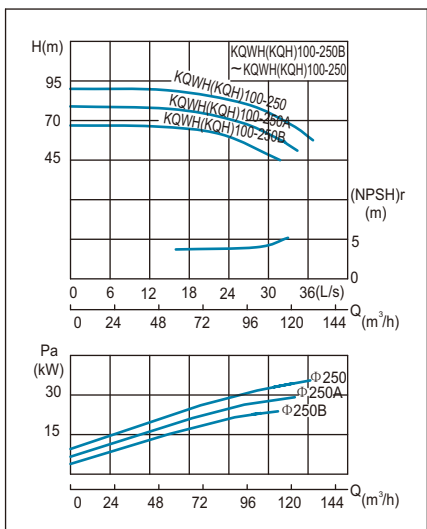

Characteristic Curve Graph

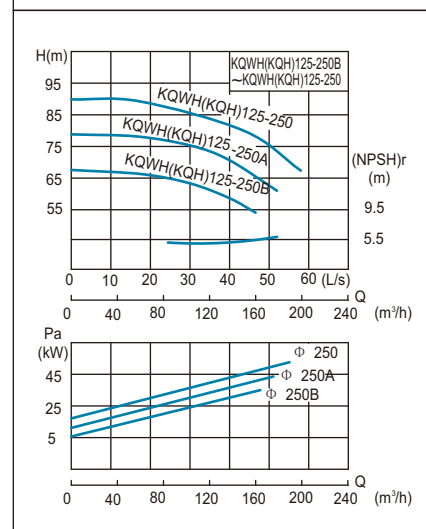
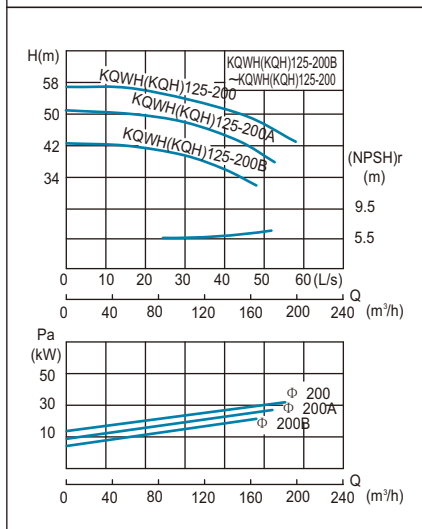
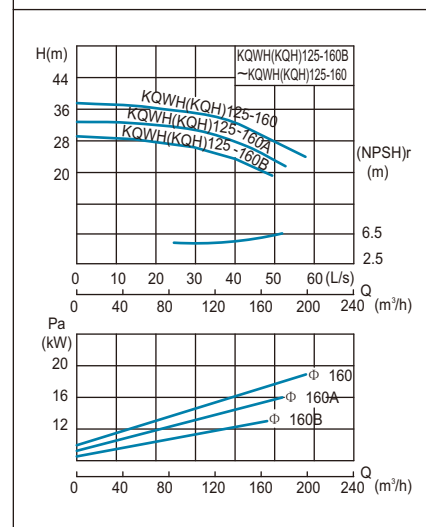
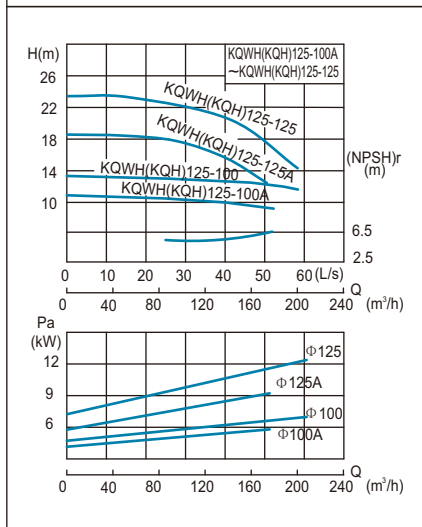
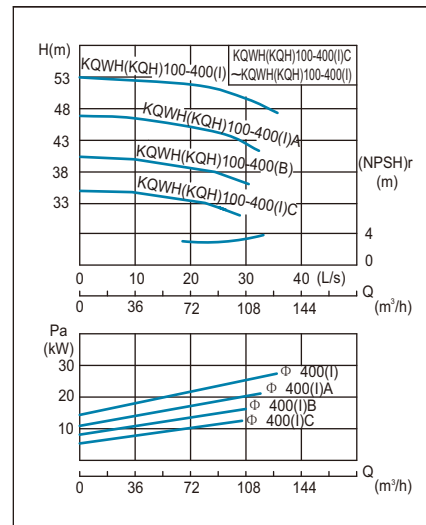
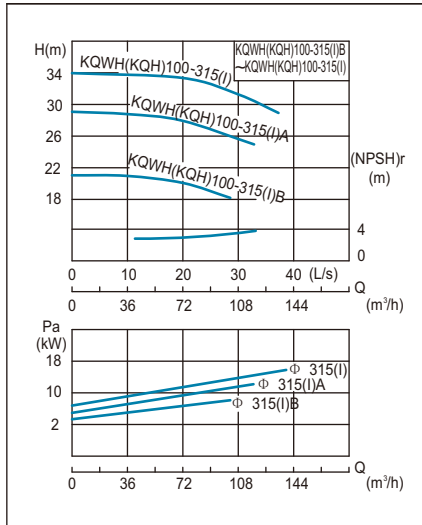

## Characteristic Curve Graph

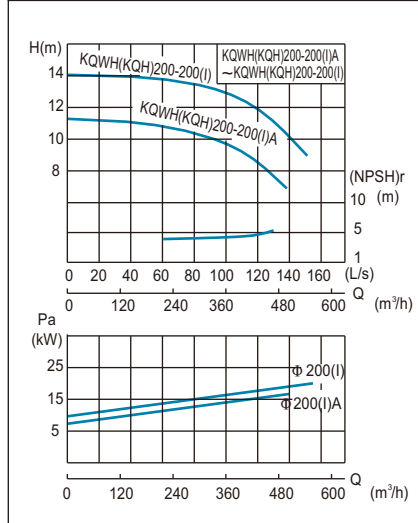
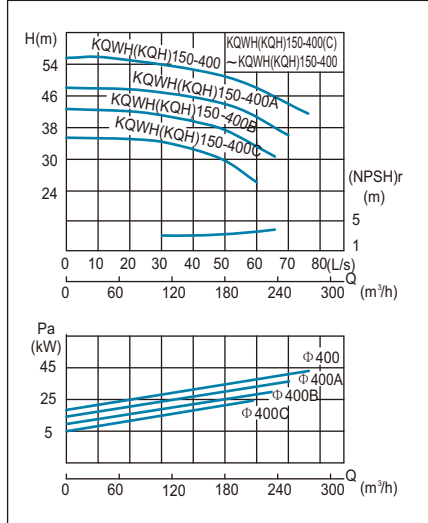
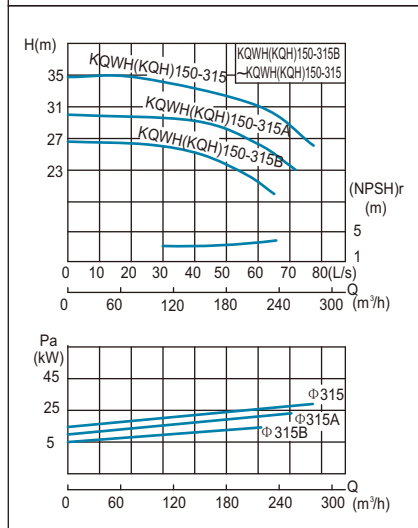
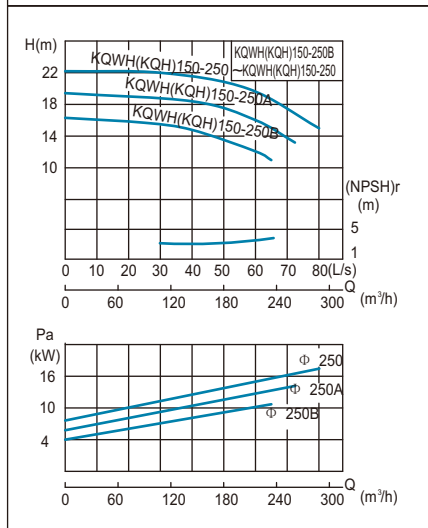
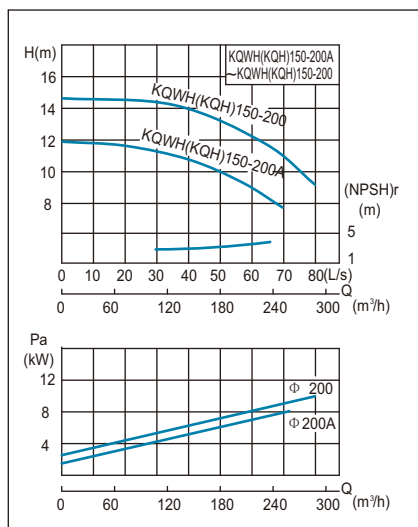
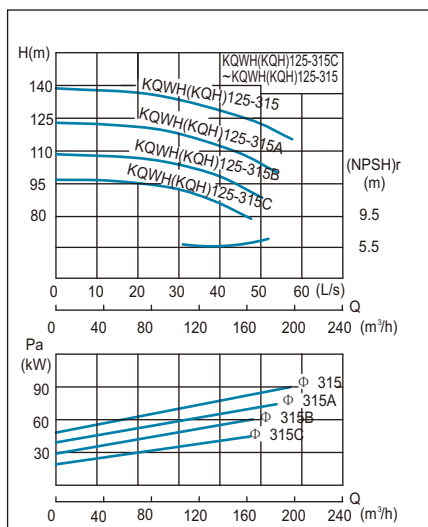

Characteristic Curve Graph

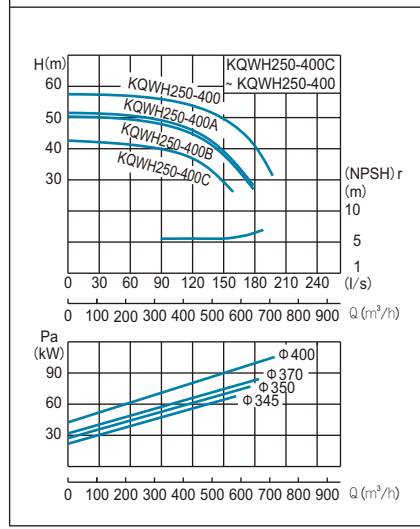
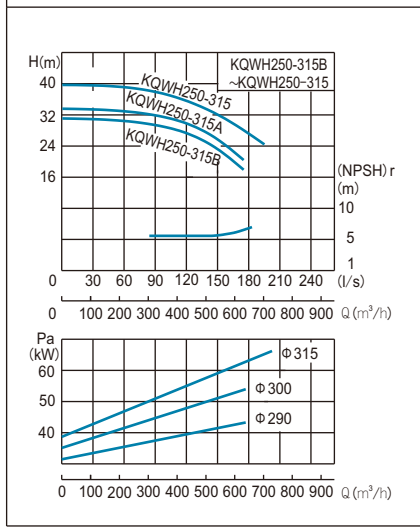
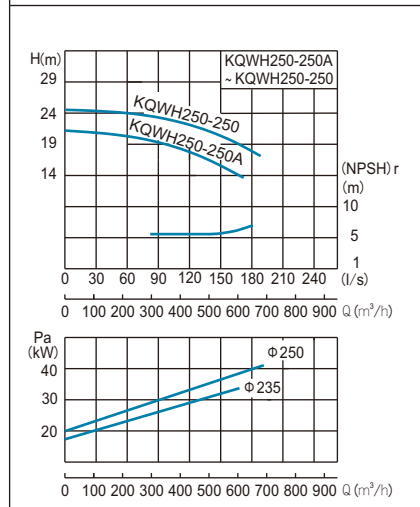
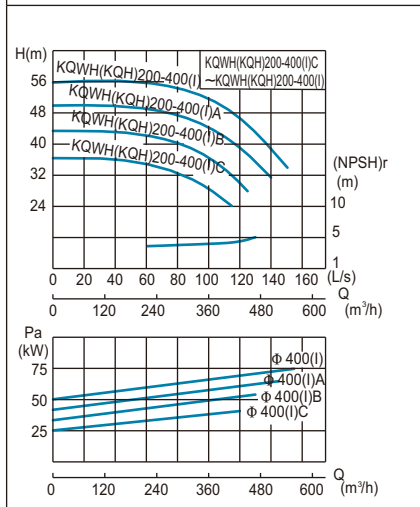
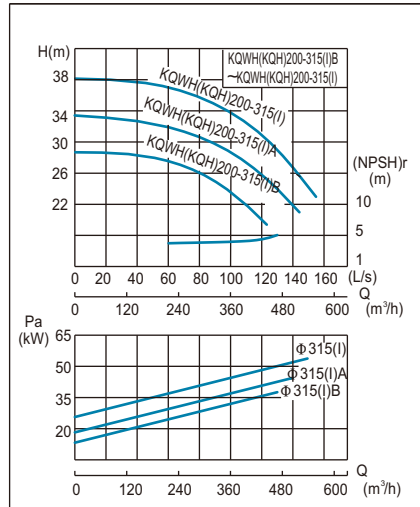
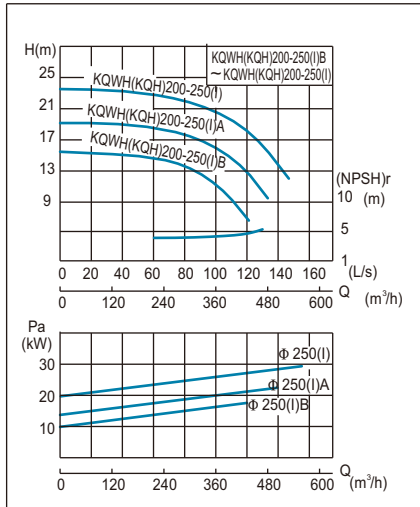

## Characteristic Curve Graph

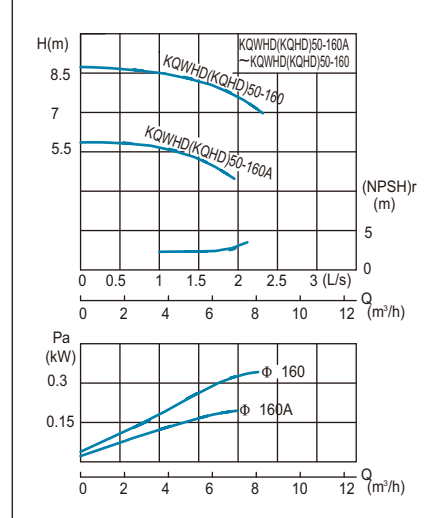
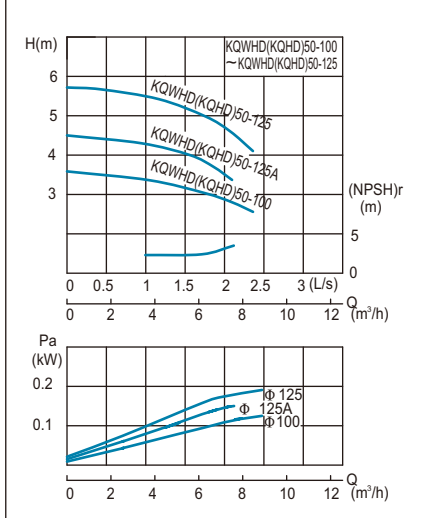
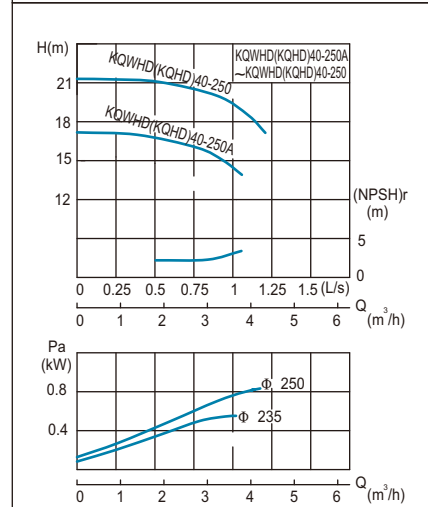
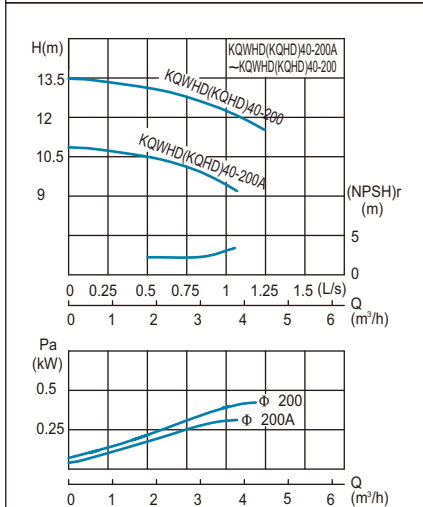
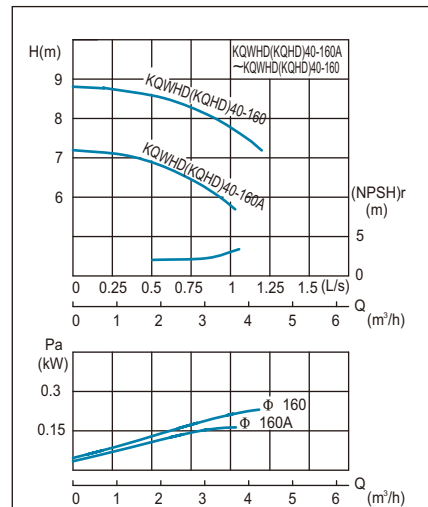
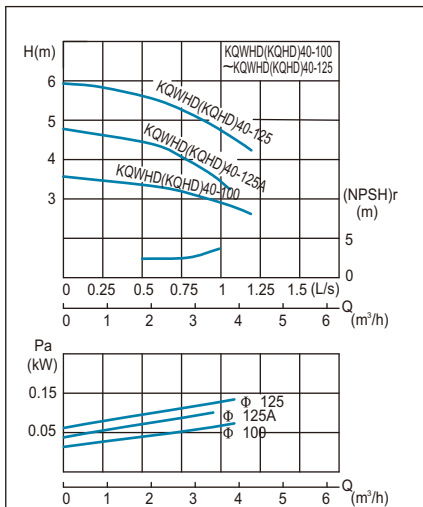

Characteristic Curve Graph

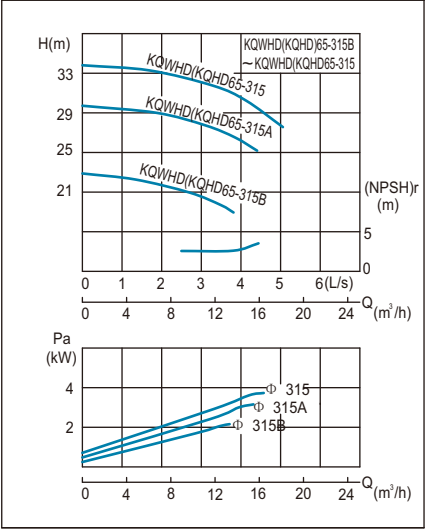
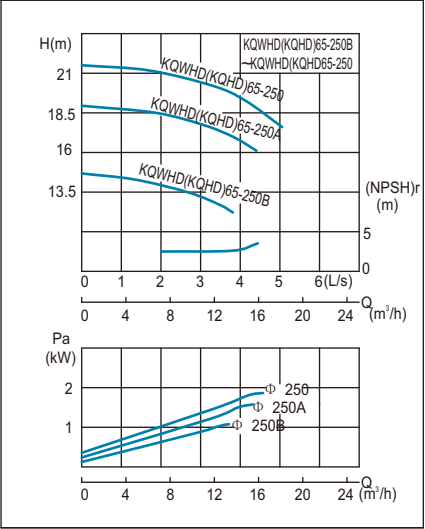
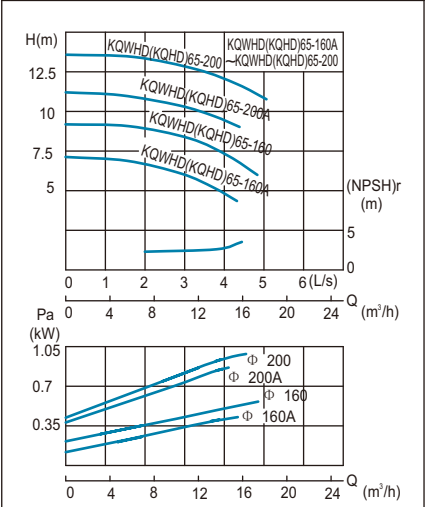
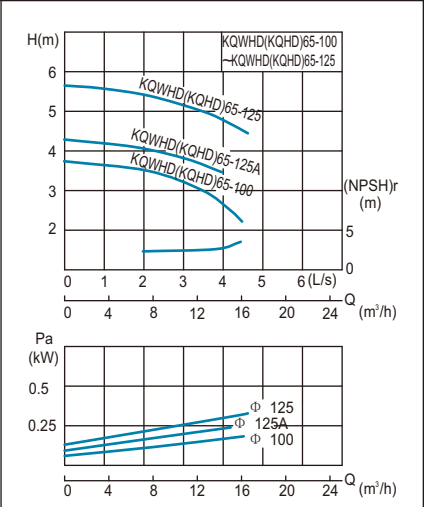
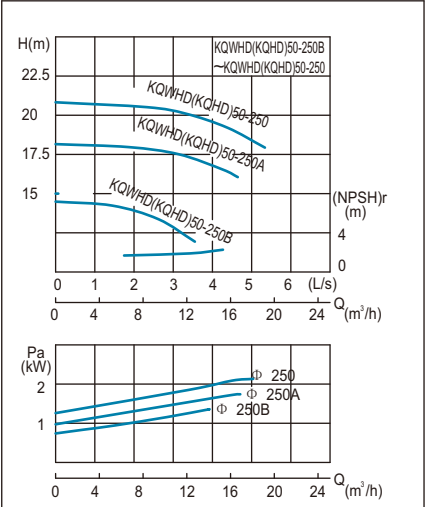
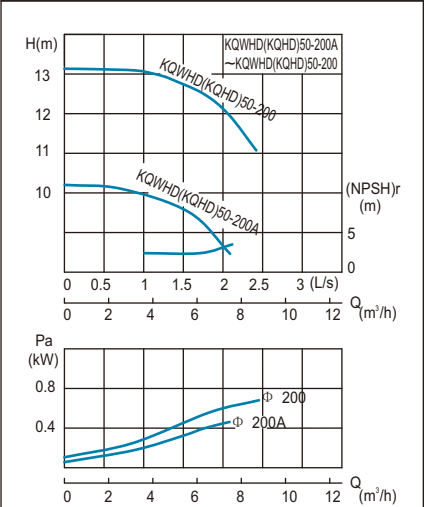

## Characteristic Curve Graph

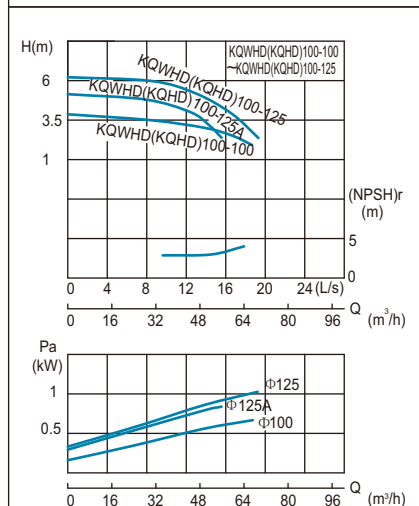
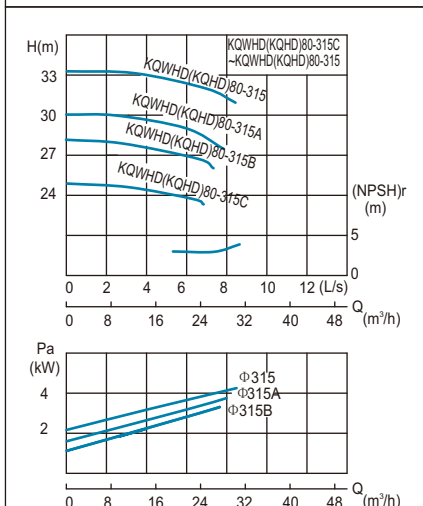
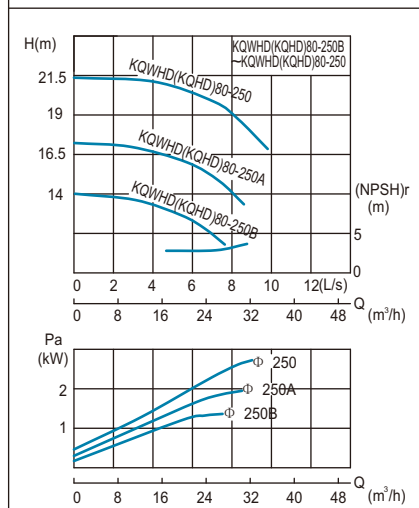
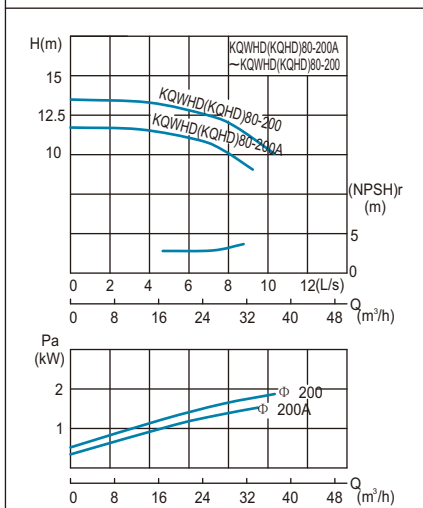
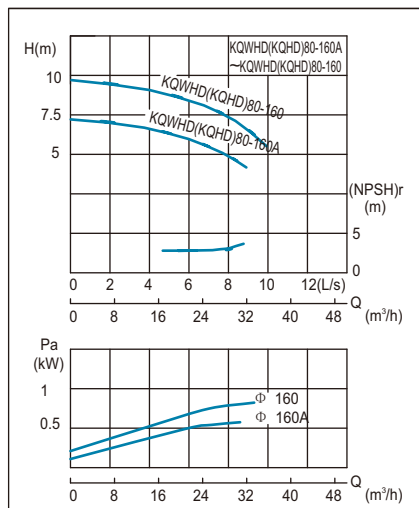
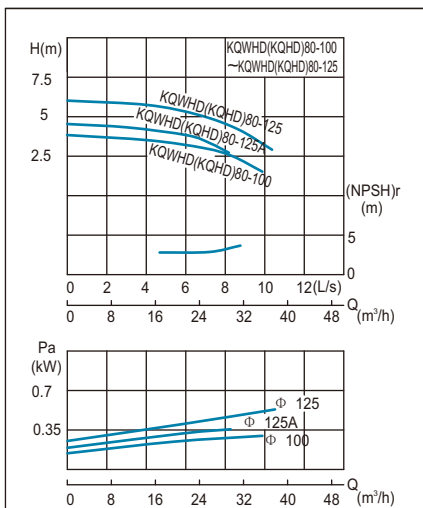

Characteristic Curve Graph

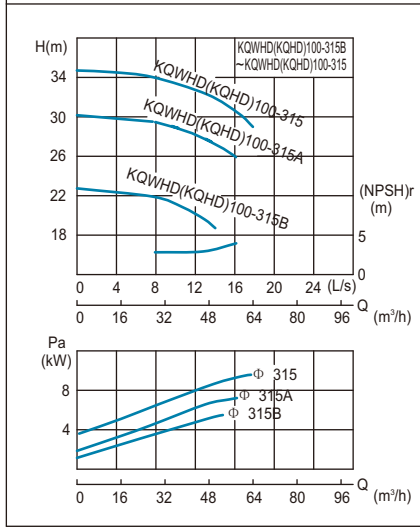
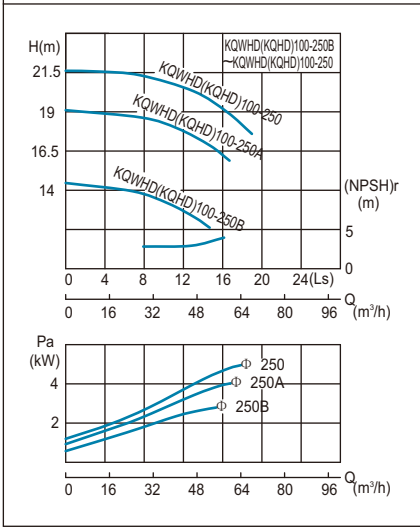
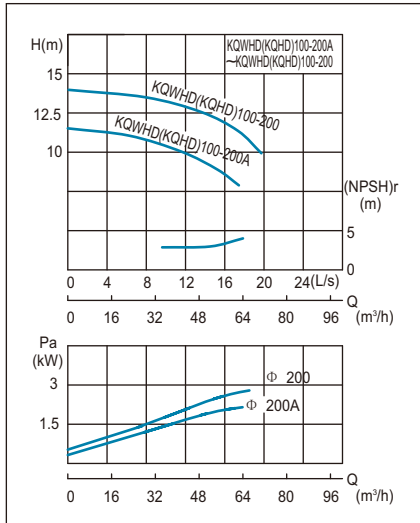
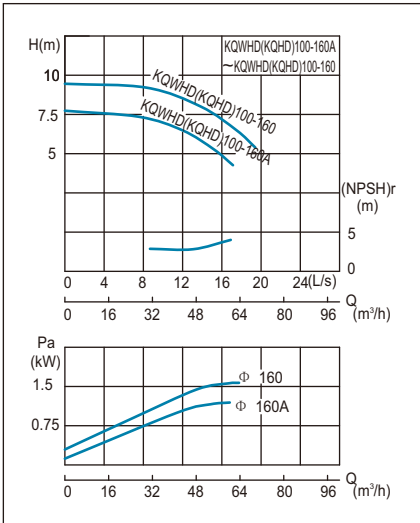

Outline and Installation Dimension Diagram of KQWH and KQWHD Horizontal Chemical Pump

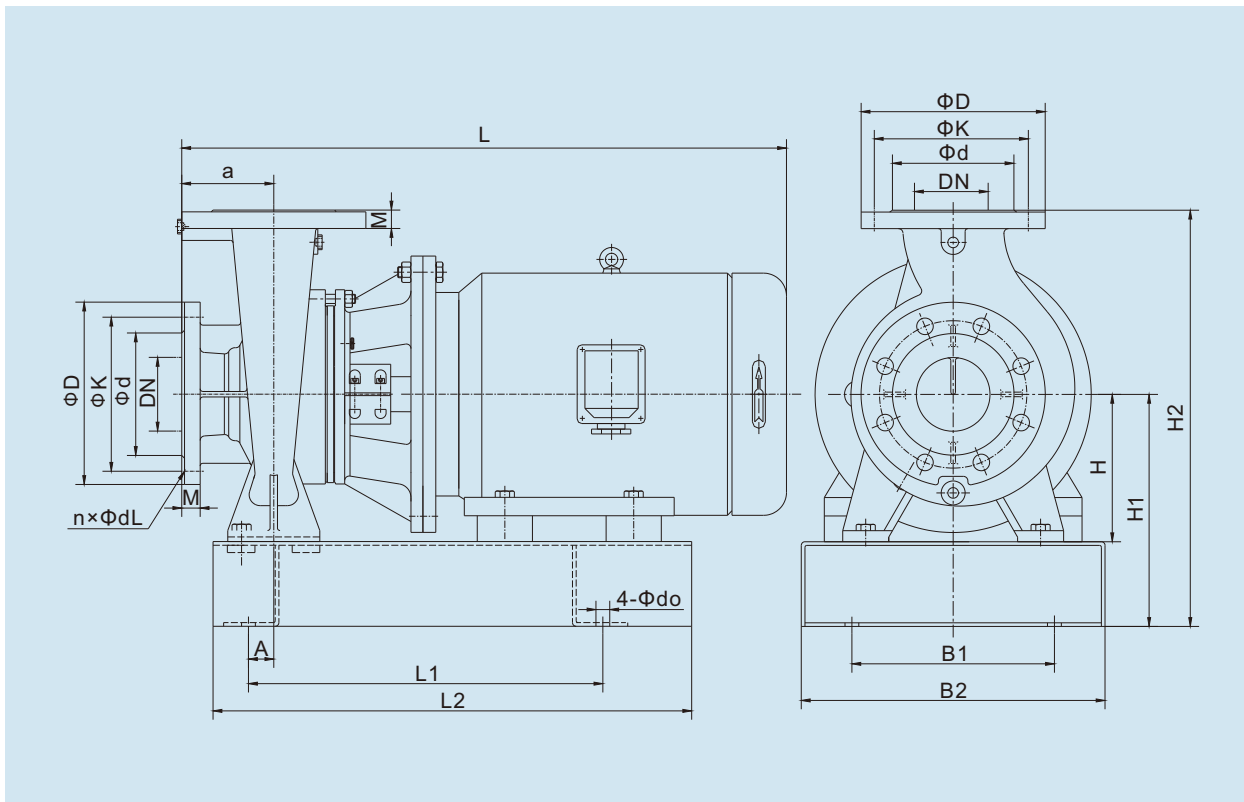

Dimension of inlet and outlet flange

DN	$\phi D$	$\phi K$	$\phi d$	M	$n \times \phi dL$
mm					
40	150	110	88	18	$4 \times \phi 18$
50	165	125	102	20	$4 \times \phi 18$
65	185	145	122	20	$4 \times \phi 18$
80	200	160	133	20	$8 \times \phi 18$
100	220	180	158	22	$8 \times \phi 18$
125	250	210	184	22	$8 \times \phi 18$
150	285	240	212	24	$8 \times \phi 22$
200	340	295	268	24	$12 \times \phi 22$
250	405	355	320	26	$12 \times \phi 26$

Outline and Installation Dimension Table of KQWH Horizontal Chemical Pump

Model	D <sub>N</sub>	L	H	a	L1	L2	A	H1	H2	B1	B2	φdo
		mm										
KQWH40-100	40	444	100	70	245	350	0	184	314	130	220	12
KQWH40-100A	40	444	100	70	245	350	0	184	314	130	220	12
KQWH40-125	40	444	110	70	245	350	0	194	344	130	220	12
KQWH40-125A	40	444	110	70	245	350	0	194	344	130	220	12
KQWH40-160	40	481	120	70	280	385	0	204	374	130	220	12
KQWH40-160A	40	456	120	70	255	385	0	204	374	130	220	12
KQWH40-160B	40	431	120	70	245	350	0	204	374	130	220	12
KQWH40-200	40	552	160	70	310	430	0	247	417	160	250	15
KQWH40-200A	40	532	160	70	310	430	0	247	417	160	250	15
KQWH40-200B	40	494	160	70	280	410	0	247	417	160	250	15
KQWH40-250	40	627	160	70	375	480	0	251	466	200	290	15
KQWH40-250A	40	627	160	70	375	480	0	251	466	200	290	15
KQWH40-250B	40	552	160	70	310	450	0	251	466	180	275	15
KQWH50-100	50	445	105	80	245	350	0	189	339	130	220	12
KQWH50-100A	50	445	105	80	245	350	0	189	339	130	220	12
KQWH50-125	50	470	110	80	255	350	0	194	344	130	220	12
KQWH50-125A	50	445	110	80	245	350	0	194	344	130	220	12
KQWH50-160	50	542	132	80	310	430	0	219	379	160	250	15
KQWH50-160A	50	504	132	80	280	410	0	219	379	160	250	15
KQWH50-160B	50	479	132	80	255	360	0	219	379	160	250	15
KQWH50-200	50	657	160	100	370	480	0	251	441	200	290	15
KQWH50-200A	50	582	160	100	310	430	0	247	437	160	250	15
KQWH50-200B	50	562	160	100	310	430	0	247	437	160	250	15
KQWH50-250	50	793	180	100	515	620	12.5	277	502	220	330	15
KQWH50-250A	50	665	180	100	395	495	12.5	277	502	220	330	15
KQWH50-250B	50	665	180	100	395	495	12.5	277	502	220	330	15
KQWH65-100	65	474	110	80	255	350	0	194	354	130	220	12
KQWH65-100A	65	454	110	80	245	350	0	194	354	130	220	12
KQWH65-125	65	542	120	80	315	410	0	206	386	130	220	12
KQWH65-125A	65	504	120	80	280	385	0	204	384	130	220	12
KQWH65-160	65	562	132	80	310	430	0	219	409	160	250	15
KQWH65-160A	65	562	132	80	310	430	0	219	409	160	250	15
KQWH65-160B	65	562	132	80	310	430	0	219	409	160	250	15
KQWH65-200	65	652	160	100	370	480	0	251	451	200	290	15
KQWH65-200A	65	652	160	100	370	480	0	251	451	200	290	15
KQWH65-200B	65	652	160	100	370	480	0	251	451	200	290	15
KQWH65-250	65	824	180	100	515	620	12.5	277	507	220	330	15
KQWH65-250A	65	824	180	100	515	620	12.5	277	507	220	330	15
KQWH65-250B	65	824	180	100	515	620	12.5	277	507	220	330	15
KQWH65-315	65	965	200	100	645	745	12.5	309	579	300	410	15
KQWH65-315A	65	887	200	100	565	670	12.5	305	575	260	355	15
KQWH65-315B	65	871	200	100	560	670	12.5	305	575	260	355	15
KQWH65-315C	65	826	200	100	515	620	12.5	305	575	260	355	15
KQWH80-100	80	562	120	100	315	410	0	206	386	130	220	12
KQWH80-100A	80	489	120	100	280	385	0	204	384	130	220	12
KQWH80-125	80	657	132	100	370	474	0	238	438	200	290	15
KQWH80-125A	80	582	132	100	340	430	0	219	419	160	250	15
KQWH80-160	80	658	160	100	370	480	0	251	451	200	290	15
KQWH80-160A	80	658	160	100	370	480	0	251	451	200	290	15

Outline and Installation Dimension Table of KQWHD Horizontal Chemical Pump

Model	D <sub>N</sub>	L	H	a	L1	L2	mm					
							A	H1	H2	B1	B2	φd <sub>o</sub>
KQWH80-160B	80	658	160	100	370	480	0	251	451	200	290	15
KQWH80-200	80	815	160	125	500	620	0	269	494	240	330	15
KQWH80-200A	80	815	160	125	500	620	0	269	494	240	330	15
KQWH80-200B	80	687	160	125	370	480	0	251	476	200	290	15
KQWH80-250	80	885	180	125	560	670	12.5	285	435	265	355	15
KQWH80-250A	80	860	180	125	550	665	12.5	277	527	240	330	15
KQWH80-250B	80	815	180	125	510	620	12.5	277	527	240	330	15
KQWH80-315	80	921	225	125	635	745	12.5	334	624	310	410	15
KQWH80-315A	80	921	225	125	635	745	12.5	334	624	310	410	15
KQWH80-315B	80	921	225	125	635	745	12.5	334	624	310	410	15
KQWH80-315C	80	912	225	125	565	670	12.5	330	620	265	355	15
KQWH100-100	100	657	160	100	365	480	12.5	251	461	200	290	15
KQWH100-100A	100	582	160	100	345	460	12.5	251	461	160	290	15
KQWH100-125	100	816	160	100	500	595	12.5	269	469	240	330	15
KQWH100-125A	100	657	160	100	365	480	12.5	251	451	200	290	15
KQWH100-160	100	826	160	100	505	620	12.5	269	519	240	330	15
KQWH100-160A	100	826	160	100	505	620	12.5	269	519	240	330	15
KQWH100-160B	100	826	160	100	505	620	12.5	269	519	240	330	15
KQWH100-200	100	887	180	100	560	670	12.5	285	535	265	355	15
KQWH100-200A	100	871	180	100	550	670	12.5	285	535	240	355	15
KQWH100-200B	100	826	180	100	505	620	12.5	285	535	240	355	15
KQWH100-250	100	1031	200	125	650	750	12.5	309	584	310	410	15
KQWH100-250A	100	1031	200	125	650	750	12.5	309	584	310	410	15
KQWH100-250B	100	1031	200	125	650	750	12.5	309	584	310	410	15
KQWH100-315	100	1305	225	125	880	1005	30	381	696	450	560	20
KQWH100-315A	100	1195	225	125	835	935	30	377	692	370	500	20
KQWH100-315B	100	1097	225	125	720	825	30	319	634	310	440	20
KQWH100-315C	100	1041	225	125	675	780	30	334	649	300	400	15
KQWH100-125(I)	100	629	180	160	340	450	12.5	285	535	265	355	15
KQWH100-160(I)	100	649	180	160	350	460	12.5	285	535	265	355	15
KQWH100-160(I)A	100	629	180	160	340	450	12.5	285	535	265	355	15
KQWH100-200(I)	100	724	250	160	410	515	30	359	659	310	410	15
KQWH100-200(I)A	100	649	250	160	370	475	30	359	659	310	410	15
KQWH100-250(I)	100	893	250	160	540	645	30	359	659	310	410	15
KQWH100-250(I)A	100	777	250	160	460	565	30	359	659	310	410	15
KQWH100-250(I)B	100	737	250	160	430	535	30	359	659	310	410	15
KQWH100-315(I)	100	931	250	160	575	685	30	359	674	310	410	20
KQWH100-315(I)A	100	886	250	160	540	645	30	359	674	310	410	20
KQWH100-315(I)B	100	730	250	160	460	565	30	359	674	310	410	20
KQWH100-400(I)	100	1093	315	160	720	830	50	417	772	370	510	20
KQWH100-400(I)A	100	1024	315	160	680	790	50	417	772	370	510	20
KQWH100-400(I)B	100	984	315	160	650	760	50	417	772	370	510	20
KQWH100-400(I)C	100	929	315	160	630	730	50	417	772	370	510	20
KQWH125-100	125	820	160	125	525	640	30	269	509	240	330	15
KQWH125-100A	125	692	160	125	400	500	30	251	491	200	290	15
KQWH125-125	125	820	160	125	525	640	30	269	519	240	330	15
KQWH125-125A	125	820	160	125	525	640	30	269	519	240	330	15
KQWH125-160	125	885	180	125	580	680	30	285	545	265	355	15
KQWH125-160A	125	860	180	125	580	680	30	285	545	240	355	15
KQWH125-160B	125	815	180	125	535	650	30	285	545	240	355	15

Outline and Installation Dimension Table of KQWHD Horizontal Chemical Pump

Model	D <sub>N</sub>	L	H	a	L1	L2	mm					
							A	H1	H2	B1	B2	φdo
KQWH125-200	125	990	200	125	650	755	30	309	594	310	400	15
KQWH125-200A	125	990	200	125	650	755	30	309	594	310	400	15
KQWH125-200B	125	885	200	125	580	680	30	309	594	265	400	15
KQWH125-250	125	1200	200	125	835	935	30	377	677	370	500	20
KQWH125-250A	125	1070	200	125	720	825	30	319	619	310	440	20
KQWH125-250B	125	1015	200	125	675	780	30	309	609	310	400	15
KQWH125-315	125	1335	225	125	935	1035	30	381	701	430	560	20
KQWH125-315A	125	1285	225	125	885	985	30	381	701	430	560	20
KQWH125-315B	125	1285	225	125	885	985	30	381	701	430	560	20
KQWH125-315C	125	1215	225	125	835	935	30	372	692	370	500	20
KQWH150-200	150	918	250	140	585	710	30	359	679	310	410	15
KQWH150-200A	150	873	250	140	540	665	30	359	679	310	410	15
KQWH150-250	150	952	250	140	600	710	30	359	719	310	410	15
KQWH150-250A	150	923	250	140	585	710	30	359	719	310	410	15
KQWH150-250B	150	878	250	140	540	665	30	359	719	310	410	15
KQWH150-315	150	1058	315	140	690	805	50	417	817	370	500	20
KQWH150-315A	150	989	315	140	660	780	50	417	817	370	510	20
KQWH150-315B	150	948	315	140	620	730	50	417	817	370	510	20
KQWH150-400	150	1137	315	140	760	870	50	417	827	370	500	20
KQWH150-400A	150	1112	315	140	760	850	50	417	827	370	500	20
KQWH150-400B	150	1066	315	140	700	810	50	417	827	370	500	20
KQWH150-400C	150	997	315	140	670	780	50	417	827	370	510	20
KQWH200-200(I)	200	980	280	160	670	780	50	382	752	370	510	20
KQWH200-200(I)A	200	940	280	160	635	735	50	382	752	370	510	20
KQWH200-250(I)	200	1063	280	160	700	813	50	382	833	370	500	20
KQWH200-250(I)A	200	998	280	160	670	780	50	382	833	370	510	20
KQWH200-250(I)B	200	858	280	160	635	735	50	382	833	370	510	20
KQWH200-315(I)	200	1250	315	160	860	970	50	421	881	430	560	20
KQWH200-315(I)A	200	1150	315	160	785	886	50	421	881	430	560	20
KQWH200-315(I)B	200	1125	315	160	760	861	50	421	881	430	560	20
KQWH200-400(I)	200	1315	315	160	905	1035	50	421	881	430	560	20
KQWH200-400(I)A	200	1315	315	160	905	1035	50	421	881	430	560	20
KQWH200-400(I)B	200	1250	315	160	860	970	50	421	881	430	560	20
KQWH200-400(I)	200	1145	315	160	780	900	50	421	881	430	560	20
KQWH250-250A	250	1120	330	200	710	890	30	439	989	500	640	20
KQWH250-250	250	1162	330	200	710	890	30	439	989	500	640	20
KQWH250-290	250	1187	330	200	735	915	30	439	989	500	640	20
KQWH250-315A	250	1282	330	200	760	987	30	439	989	500	640	20
KQWH250-315	250	1342	330	200	820	1042	30	439	989	500	640	20
KQWH250-400C	250	1340	355	200	910	1060	50	467	1067	480	640	20
KQWH250-400B	250	1340	355	200	910	1060	50	467	1067	480	640	20
KQWH250-400A	250	1390	355	200	960	1110	50	467	1067	480	640	20
KQWH250-400	250	1390	355	200	960	1110	50	467	1067	480	640	20

Outline and Installation Dimension Table of KQWHD Horizontal Chemical Pump

Model	D <sub>N</sub>	L	H	a	L1	L2	mm					
							A	H1	H2	B1	B2	φdo
KQWHD40-100	40	444	100	70	245	350	0	184	314	130	220	12
KQWHD40-125	40	444	110	70	245	350	0	194	344	130	220	12
KQWHD40-125A	40	444	110	70	245	350	0	194	344	130	220	12
KQWHD40-160	40	431	120	70	245	350	0	204	374	130	220	12
KQWHD40-160A	40	431	120	70	245	350	0	204	374	130	220	12
KQWHD40-200	40	447	160	70	280	360	0	247	417	160	250	15
KQWHD40-200A	40	447	160	70	280	360	0	247	417	160	250	15
KQWHD40-250	40	484	160	70	280	385	0	251	466	200	290	15
KQWHD40-250A	40	447	160	70	260	375	0	251	466	180	275	15
KQWHD40-250B	40	447	160	70	260	375	0	251	466	180	275	15
KQWHD50-100	50	444	105	80	245	350	0	189	339	130	220	12
KQWHD50-125	50	445	110	80	245	350	0	194	344	130	220	12

## Outline and Installation Dimension Table of KQWHD Horizontal Chemical Pump

Model	D <sub>N</sub>	L	H	a	L1	L2	A	H1	H2	B1	B2	φdo
		mm										
KQWHD50-125A	50	445	110	80	245	350	0	194	344	130	220	12
KQWHD50-160	50	460	132	80	260	370	0	219	379	160	250	12
KQWHD50-160A	50	460	132	80	260	370	0	219	379	160	250	12
KQWHD50-200	50	467	160	100	280	360	0	251	441	200	290	15
KQWHD50-200A	50	467	160	100	280	360	0	251	441	200	290	15
KQWHD50-250	50	528	180	100	335	435	12.5	277	502	220	330	15
KQWHD50-250A	50	522	180	100	305	405	12.5	277	502	220	330	15
KQWHD50-250B	50	485	180	100	305	405	12.5	277	502	220	330	15
KQWHD65-100	65	454	110	80	245	350	0	194	354	130	220	12
KQWHD65-125	65	454	120	80	245	350	0	204	384	130	220	12
KQWHD65-125A	65	454	120	80	245	350	0	204	384	130	220	12
KQWHD65-160	65	447	132	80	260	370	0	219	409	160	250	12
KQWHD65-160A	65	447	132	80	260	370	0	219	409	160	250	12
KQWHD65-200	65	489	160	100	280	385	0	251	451	200	290	15
KQWHD65-200A	65	472	160	100	260	365	0	251	451	200	290	15
KQWHD65-250	65	573	180	100	365	470	12.5	277	507	220	330	15
KQWHD65-250A	65	528	180	100	335	435	12.5	277	507	220	330	15
KQWHD65-250B	65	528	180	100	310	410	12.5	277	507	220	330	15
KQWHD65-315	65	595	200	100	390	500	12.5	309	579	310	410	15
KQWHD65-315A	65	595	200	100	390	500	12.5	309	579	310	410	15
KQWHD65-315B	65	595	200	100	390	500	12.5	309	579	310	410	15
KQWHD80-100	80	483	120	100	245	350	0	204	384	130	220	12
KQWHD80-125	80	490	132	100	245	350	0	219	419	160	250	12
KQWHD80-125A	80	490	132	100	245	350	0	219	419	160	250	12
KQWHD80-160	80	494	160	100	265	365	0	251	451	200	290	15
KQWHD80-160A	80	477	160	100	260	365	0	251	451	200	290	15
KQWHD80-200	80	592	160	125	340	445	0	251	476	200	290	15
KQWHD80-200A	80	554	160	125	310	415	0	251	476	200	290	15
KQWHD80-250	80	595	180	125	350	450	12.5	285	535	265	355	15
KQWHD80-250A	80	595	180	125	350	450	12.5	285	535	265	355	15
KQWHD80-250B	80	560	180	125	330	430	12.5	277	527	240	330	15
KQWHD80-315	80	695	225	125	390	500	12.5	334	624	310	410	15
KQWHD80-315A	80	620	225	125	390	500	12.5	334	624	310	410	15
KQWHD80-315B	80	620	225	125	390	500	12.5	334	624	310	410	15
KQWHD100-100	100	510	160	100	290	400	12.5	251	451	200	290	12
KQWHD100-125	100	530	160	100	325	435	12.5	251	451	240	330	15
KQWHD100-125A	100	530	160	100	325	435	12.5	251	451	240	330	15
KQWHD100-160	100	575	160	100	355	465	12.5	257	507	240	330	15
KQWHD100-160A	100	540	160	100	325	435	12.5	257	507	240	330	15
KQWHD100-200	100	575	180	100	360	465	12.5	285	535	265	355	15
KQWHD100-200A	100	575	180	100	360	465	12.5	285	535	265	355	15
KQWHD100-250	100	705	200	125	410	530	12.5	305	580	265	355	15
KQWHD100-250A	100	630	200	125	390	490	12.5	305	580	265	355	15
KQWHD100-250B	100	630	200	125	390	490	12.5	305	580	265	355	15
KQWHD100-315	100	840	225	125	550	660	30	334	649	300	400	15
KQWHD100-315A	100	746	225	125	500	605	30	339	654	310	410	20
KQWHD100-315B	100	706	225	125	460	565	30	339	654	310	410	20

Outline and Installation Dimension Diagram of KQH and KQHD Vertical Chemical Pump

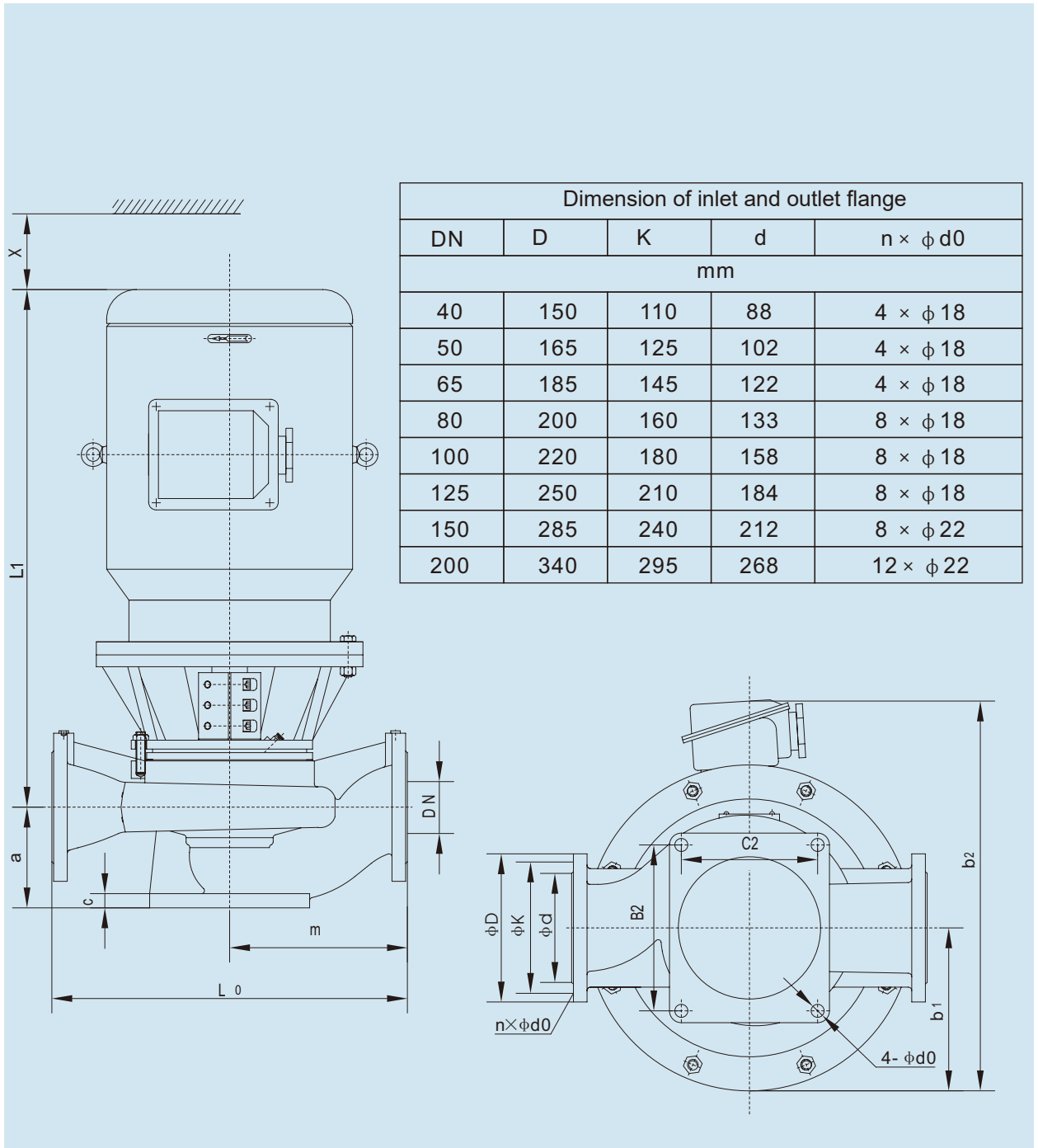

Outline and Installation Dimension Table of KQH Vertical Chemical Pump

Model	D <sub>N</sub>	L <sub>0</sub>	m	a	c	L <sub>1</sub>	b1	b2	x	C <sub>2</sub> ×B <sub>2</sub>	do
KQH40-100	40	260	130	85	15	374	100	250	100	70×120	14
KQH40-100A	40	260	130	85	15	350	120	245	100	70×120	14
KQH40-125	40	300	150	85	15	374	184	274	100	70×120	14
KQH40-125A	40	300	150	85	15	374	184	274	100	70×120	14
KQH40-160	40	340	170	90	15	434	115	275	100	70×120	14
KQH40-160A	40	340	170	90	15	434	115	275	100	70×120	14
KQH40-160B	40	340	170	90	15	399	115	275	100	70×120	14
KQH40-200	40	350	180	93	15	482	139	330	100	80×130	14
KQH40-200A	40	350	180	93	15	462	139	320	100	80×130	14
KQH40-200B	40	350	180	93	15	424	139	299	100	80×130	14
KQH40-250	40	430	215	94	17	557	160	370	100	80×130	14
KQH40-250A	40	430	215	94	17	557	160	370	100	80×130	14
KQH40-250B	40	430	215	94	17	482	160	350	100	80×130	14
KQH50-100	50	300	150	93	15	365	100	250	100	80×130	14
KQH50-100A	50	300	150	93	15	365	100	250	100	80×130	14
KQH50-125	50	300	150	90	15	394	100	260	100	80×130	14
KQH50-125A	50	300	150	90	15	374	100	250	100	80×130	14
KQH50-160	50	320	160	101	15	462	117	297	100	80×130	14
KQH50-160A	50	320	160	101	15	434	117	297	100	80×130	14
KQH50-160B	50	320	160	101	15	389	117	297	100	80×130	14
KQH50-200	50	380	190	98	18	557	139	349	120	80×130	14
KQH50-200A	50	380	190	98	18	482	139	329	120	80×130	14
KQH50-200B	50	380	190	98	18	462	139	319	120	80×130	14
KQH50-250	50	450	225	105	20	724	200	465	120	100×160	18
KQH50-250A	50	450	225	105	20	565	200	410	120	100×160	18
KQH50-250B	50	450	225	105	20	565	200	410	120	100×160	18
KQH65-100	65	330	170	105	18	394	100	260	105	100×160	18
KQH65-100A	65	330	170	105	18	374	100	250	105	100×160	18
KQH65-125	65	360	180	97	18	467	125	305	105	100×160	18
KQH65-125A	65	360	180	97	18	424	100	260	105	100×160	18
KQH65-160	65	380	190	100	20	482	125	315	105	100×160	18
KQH65-160A	65	380	190	100	20	482	125	315	105	100×160	18
KQH65-160B	65	380	190	100	20	462	125	305	105	100×160	18
KQH65-200	65	400	200	105	20	562	150	360	105	100×160	18
KQH65-200A	65	400	200	105	20	562	150	360	105	100×160	18
KQH65-200B	65	400	200	105	20	562	150	360	105	100×160	18
KQH65-250	65	460	230	110	24	724	175	440	105	120×180	18
KQH65-250A	65	460	230	110	24	724	175	440	105	120×180	18
KQH65-250B	65	460	230	110	24	724	175	440	105	120×180	18
KQH65-315	65	540	270	120	20	896	270	580	110	150×240	22
KQH65-315A	65	540	270	120	20	787	270	555	110	150×240	22
KQH65-315B	65	540	270	120	20	771	270	525	110	150×240	22
KQH65-315C	65	540	270	120	20	771	270	525	110	150×240	22
KQH80-100	80	370	190	118	18	462	125	305	110	100×160	18
KQH80-100A	80	370	190	118	18	424	100	260	110	100×160	18
KQH80-125	80	400	200	122	15	557	138	348	110	100×160	18
KQH80-125A	80	400	200	122	15	482	125	315	110	100×160	18
KQH80-160	80	410	210	126	20	557	138	348	110	100×160	18
KQH80-160A	80	410	210	126	20	557	138	348	110	100×160	18

Outline and Installation Dimension Table of KQH Vertical Chemical Pump

Model	D <sub>N</sub>	L <sub>0</sub>	m	a	c	L <sub>1</sub>	b1	b2	x	C <sub>2</sub> xB <sub>2</sub>	do
		mm									
KQH80-160B	80	410	210	126	20	555	138	348	110	100×160	18
KQH80-200	80	450	225	125	20	690	154	367	120	100×160	18
KQH80-200A	80	450	225	125	20	690	154	367	120	100×160	18
KQH80-200B	80	450	225	125	20	560	154	367	120	100×160	18
KQH80-250	80	500	250	132	23	760	168	433	120	120×180	18
KQH80-250A	80	500	250	132	23	735	168	433	120	120×180	18
KQH80-250B	80	500	250	132	23	690	168	433	120	120×180	18
KQH80-315	80	580	290	140	20	870	210	525	120	150×240	22
KQH80-315A	80	580	290	140	20	870	210	525	120	150×240	22
KQH80-315B	80	580	290	140	20	870	210	525	120	150×240	22
KQH80-315C	80	580	290	140	20	765	190	475	120	150×240	22
KQH100-100	100	435	225	140	20	555	150	360	130	120×180	18
KQH100-100A	100	435	225	140	20	480	125	315	130	120×180	18
KQH100-125	100	420	220	140	22	685	168	433	130	120×180	18
KQH100-125A	100	420	220	140	22	555	150	360	130	120×180	18
KQH100-160	100	500	250	157	22	695	175	440	130	120×180	18
KQH100-160A	100	500	250	157	22	695	175	440	130	120×180	18
KQH100-160B	100	500	250	157	22	695	175	440	130	120×180	18
KQH100-200	100	500	250	137	22	765	190	475	130	120×180	18
KQH100-200A	100	500	250	137	22	740	175	440	130	120×180	18
KQH100-200B	100	500	250	137	22	695	175	440	130	120×180	18
KQH100-250	100	560	285	155	30	870	210	525	130	150×240	22
KQH100-250A	100	560	285	155	30	870	210	525	130	150×240	22
KQH100-250B	100	560	285	155	30	870	210	525	130	150×240	22
KQH100-315	100	640	325	165	20	1120	292	703	130	210×260	22
KQH100-315A	100	640	325	165	20	1050	258	643	130	210×260	22
KQH100-315B	100	640	325	165	20	935	238	583	130	210×260	22
KQH100-315C	100	640	325	165	20	880	210	525	130	210×260	22
KQH100-125(I)	100	525	275	167	20	467	145	335	130	120×180	18
KQH100-160(I)	100	525	275	167	20	487	145	335	130	120×180	18
KQH100-160(I)A	100	525	275	167	20	467	145	335	130	120×180	18
KQH100-200(I)	100	615	315	175	20	562	176	385	130	120×180	18
KQH100-200(I)A	100	615	315	175	20	487	176	383	130	120×180	18
KQH100-250(I)	100	615	315	175	20	685	176	441	130	150×240	22
KQH100-250(I)A	100	615	315	175	20	602	176	385	130	150×240	22
KQH100-250(I)B	100	615	315	175	20	562	176	385	130	150×240	22
KQH100-315(I)	100	645	330	185	25	730	200	465	130	210×260	22
KQH100-315(I)A	100	645	330	185	25	685	200	465	130	210×260	22
KQH100-315(I)B	100	645	330	185	25	602	200	431	130	210×260	22
KQH100-400(I)	100	725	370	180	25	892	236	551	130	210×260	22
KQH100-400(I)A	100	725	370	180	25	827	236	521	130	210×260	22
KQH100-400(I)B	100	725	370	180	25	787	236	521	130	210×260	22
KQH100-400(I)C	100	725	370	180	25	745	236	491	130	210×260	22
KQH125-100	125	495	255	165	25	693	168	433	130	150×240	22
KQH125-100A	125	495	255	165	25	563	140	350	130	150×240	22
KQH125-125	125	510	260	170	25	693	168	433	130	150×240	22
KQH125-125A	125	510	260	170	25	693	168	433	130	150×240	22
KQH125-160	125	530	270	175	30	763	175	440	130	150×240	22
KQH125-160A	125	530	270	175	30	738	175	440	130	150×240	22
KQH125-160B	125	530	270	175	30	693	175	440	130	150×240	22

**Outline and Installation Dimension Table of KQH Vertical Chemical Pump**

Model	D <sub>N</sub>	L <sub>0</sub>	m	a	c	L <sub>1</sub>	b1	b2	x	C <sub>2</sub> xB <sub>2</sub>	do
		mm									
KQH125-200	125	570	285	175	30	865	210	525	140	210×260	22
KQH125-200A	125	570	285	175	30	865	210	525	140	210×260	22
KQH125-200B	125	570	285	175	30	760	190	475	140	210×260	22
KQH125-250	125	600	300	170	35	1075	258	680	140	230×280	22
KQH125-250A	125	600	300	170	35	945	238	583	140	230×280	22
KQH125-250B	125	600	300	170	35	890	200	525	140	230×280	22
KQH125-315	125	650	330	180	35	1230	293	703	140	230×280	22
KQH125-315A	125	650	330	180	35	1280	293	703	140	230×280	22
KQH125-315B	125	650	330	180	35	1180	278	703	140	230×280	22
KQH125-315C	125	650	330	180	35	1004	258	643	140	230×280	22
KQH150-200	150	690	370	200	30	770	181	446	150	210×260	22
KQH150-200A	150	690	370	200	30	733	181	446	150	210×260	22
KQH150-250	150	730	370	205	30	812	190	475	150	210×260	22
KQH150-250A	150	730	370	205	30	733	188	453	150	210×260	22
KQH150-250B	150	730	370	205	30	738	188	453	150	210×260	22
KQH150-315	150	800	400	205	30	918	227	542	155	210×260	22
KQH150-315A	150	800	400	205	30	849	227	512	155	210×260	22
KQH150-315B	150	800	400	205	30	809	227	512	155	210×260	22
KQH150-400	150	840	430	210	35	997	247	592	155	230×280	22
KQH150-400A	150	840	430	210	35	972	247	582	155	230×280	22
KQH150-400B	150	840	430	210	35	926	247	562	155	230×280	22
KQH150-400C	150	840	430	210	35	857	247	532	155	230×280	22
KQH200-200(I)	200	820	450	240	32	825	217	511	150	230×280	22
KQH200-200(I)A	200	820	450	240	32	785	217	511	150	230×280	22
KQH200-250(I)A	200	900	450	240	32	838	220	497	150	230×280	22
KQH200-250(I)	200	900	450	240	32	903	220	497	150	230×280	22
KQH200-250(I)B	200	900	450	240	32	798	220	497	150	230×280	22
KQH200-315(I)	200	960	500	250	35	1090	275	660	155	300×400	22
KQH200-315(I)A	200	960	500	250	35	990	275	660	155	300×400	22
KQH200-315(I)B	200	960	500	250	35	960	275	660	155	300×400	22
KQH200-400(I)	200	960	500	260	35	1155	275	685	155	300×400	22
KQH200-400(I)A	200	960	500	260	35	1155	275	685	155	300×400	22
KQH200-400(I)B	200	960	500	260	35	1085	275	685	155	300×400	22
KQH200-400(I)C	200	960	500	260	35	1012	275	685	155	300×400	22

**Outline and Installation Dimension Table of KQHD Vertical Chemical Pump**

Model	D <sub>N</sub>	L <sub>0</sub>	m	a	c	L <sub>1</sub>	b1	b2	x	C <sub>2</sub> xB <sub>2</sub>	do
		mm									
KQHD40-100	40	260	130	85	15	325	120	235	100	70×120	14
KQHD40-125	40	300	150	85	15	325	120	235	100	70×120	14
KQHD40-125A	40	300	150	85	15	325	120	235	100	70×120	14
KQHD40-160	40	340	170	90	15	340	120	240	100	70×120	14
KQHD40-160A	40	340	170	90	15	325	120	235	100	70×120	14
KQHD40-200	40	350	180	93	18	365	155	315	100	80×130	14
KQHD40-200A	40	350	180	93	18	340	155	315	100	80×130	14
KQHD40-250	40	430	215	94	17	440	160	320	100	80×130	14
KQHD40-250A	40	430	215	94	17	400	160	320	100	80×130	14
KQHD40-250B	40	430	215	94	17	400	160	320	100	80×130	14
KQHD50-100	50	300	150	93	15	325	120	235	100	80×130	14
KQHD50-125	50	300	150	90	15	340	120	240	100	80×130	14

Outline and Installation Dimension Table of KQHD Vertical Chemical Pump

Model	D <sub>N</sub>	L <sub>0</sub>	m	a	c	L <sub>1</sub>	b1	b2	x	C <sub>2</sub> xB <sub>2</sub>	do
		mm									
KQHD50-125A	50	300	150	90	15	325	120	235	100	80×130	14
KQHD50-160	50	320	160	101	15	365	120	265	100	80×130	14
KQHD50-160A	50	320	160	101	15	340	120	240	100	80×130	14
KQHD50-200	50	380	190	98	18	370	155	310	120	80×130	14
KQHD50-200A	50	380	190	98	18	370	155	310	120	80×130	14
KQHD50-250	50	450	225	105	20	430	200	365	120	100×160	18
KQHD50-250A	50	450	225	105	20	410	200	365	120	100×160	18
KQHD50-250B	50	450	225	105	20	390	200	355	120	100×160	18
KQHD65-100	65	330	170	105	18	340	120	240	105	100×160	18
KQHD65-125	65	360	180	97	18	340	120	240	105	100×160	18
KQHD65-125A	65	360	180	97	18	340	120	240	105	100×160	18
KQHD65-160	65	380	190	100	20	362	120	270	105	100×160	18
KQHD65-160A	65	380	190	100	20	340	120	240	105	100×160	18
KQHD65-200	65	400	200	105	20	397	155	320	105	100×160	18
KQHD65-200A	65	400	200	105	20	372	155	320	105	100×160	18
KQHD65-250	65	460	230	110	24	470	155	335	105	120×180	18
KQHD65-250A	65	460	230	110	24	442	155	320	105	120×180	18
KQHD65-250B	65	460	230	110	24	397	155	320	105	120×180	18
KQHD65-315	65	540	270	120	20	515	270	510	105	150×240	22
KQHD65-315A	65	540	270	120	20	505	270	510	105	150×240	22
KQHD65-315B	65	540	270	120	20	505	270	490	105	150×240	22
KQHD65-315C	65	540	270	120	20	485	270	490	105	150×240	22
KQHD80-100	80	370	190	118	18	340	120	240	110	100×160	18
KQHD80-125	80	400	200	122	15	362	120	270	110	100×160	18
KQHD80-125A	80	400	200	122	15	362	120	270	110	100×160	18
KQHD80-160	80	410	210	126	20	387	120	280	110	100×160	18
KQHD80-160A	80	410	210	126	20	362	120	270	110	100×160	18
KQHD80-200	80	450	225	125	20	470	155	335	120	100×160	18
KQHD80-200A	80	450	225	125	20	432	155	315	120	100×160	18
KQHD80-250	80	500	250	132	25	470	155	335	120	120×180	18
KQHD80-250A	80	500	250	132	25	470	155	335	120	120×180	18
KQHD80-250B	80	500	250	132	25	432	155	315	120	120×180	18
KQHD80-315	80	580	290	140	25	565	210	545	120	150×240	22
KQHD80-315A	80	580	290	140	25	490	210	545	120	150×240	22
KQHD80-315B	80	580	290	140	25	470	210	545	120	150×240	22
KQHD100-100	100	435	225	140	20	385	120	270	130	120×180	18
KQHD100-125	100	450	225	140	22	405	130	290	130	120×180	18
KQHD100-125A	100	450	225	140	22	405	130	290	130	120×180	18
KQHD100-160	100	500	250	157	22	465	130	310	130	120×180	18
KQHD100-160A	100	500	250	157	22	430	130	290	130	120×180	18
KQHD100-200	100	500	250	137	22	470	170	360	130	120×180	18
KQHD100-200A	100	500	250	137	22	470	170	350	130	120×180	18
KQHD100-250	100	560	285	155	30	565	170	380	130	150×240	22
KQHD100-250A	100	560	285	155	30	490	170	360	130	150×240	22
KQHD100-250B	100	560	285	155	30	470	170	350	130	150×240	22
KQHD100-315	100	640	325	165	20	698	205	470	130	210×260	22
KQHD100-315A	100	640	325	165	20	580	205	415	130	210×260	22
KQHD100-315B	100	640	325	165	20	540	205	415	130	210×260	22

Reference Table for Medium Selection of Chemical Pump

Corrosion data of Cr13 stainless steel Table 1											
Medium	Concentration	Temperature °C				Medium	Concentration	Temperature °C			
	%	25	50	80	100		%	25	50	80	100
Nitric acid	<20	√	√	√		Methanol		√	√	√	√
	20~80	√	√	√	○	Ethanol		√	√	√	√
	80~90	√	○			Propanol		√	√	√	√
Phosphoric acid (aerated)	10	√	√	√		Glycol		√	√	√	√
	20~30	√	√	√		Acetone	<100	√	√	√	×
Formic acid	10	√	√	×			100	√	√	√	√
	20~90	○	×			Butanone	<100	√	√	√	√
Acetic acid	10	√	×				100	√	√	√	√
Sodium hydroxide	<30	√	√	√	√	Crude oil (1.5% sulfur)		√	√	√	√
	40~50	√	√	○	○	Crude oil (containing high sulfur)		○			
Potassium hydroxide	<50	√	√	√	√	Gasoline (sulfur < 1%)		√	√	√	
	50	√	√	√	×	Gasoline (sulfur)		×			
Calcium hydroxide	10	√	√	√	√	Vinegar		○			
Sodium chloride	10	√	×			Alcohol		○			
	20	√	√	√	√	Beer		○			
Fresh water		√				Milk		√			
Distilled water		√				Vegetable oil		√			
Seawater		○				Acid mineral water		○			

Symbol description: √ Good corrosion resistance  
 ○ It's available, but it's rotten  
 × Not applicable

## Reference Table for Medium Selection of Chemical Pump

Medium	Concentration %	Temperature °C				Medium	Concentration %	Temperature °C			
		25	50	80	100			25	50	80	100
Sulfuric acid (non aerated)	<5	√			×	Sodium hydroxide	<50	√	○	○	×
	10~80	×	×			Potassium hydroxide	<50	√	√	√	√
	90	√	×				60~70	√	√	√	○
	100	√	○								
Sulfuric acid (aerated)	<20	○	×			Calcium hydroxide	<28	√	√	√	√
	30~60	×	×			Sodium chloride	10~30	√	√	√	√
	70~80	○	×			Methanol	<100	√	√	√	√
Nitric acid	<30	√	√	√	√	Ethanol		√	√	√	√
	40~60	√	√	√	√						
	70	√	√	√	○	Acetone	10~100	√	√	√	√
	80	√	√	○	○						
	90	√	○	○	×	Butanone		√	√	√	√
	100	√	×			Crude oil		√	√	√	√
Phosphoric acid	<5	√	√	√	√	Gasoline		√	√	√	
	10	√	×			kerosene		√	√	√	√
Formic acid	<5	√	√	√	√	Vinegar		√	√	√	√
	>5	×				Beer		√	√	√	
Acetic acid (not inflated)	<20	√	√	√	√	Milk		√	√	√	√
	30~60	○	○	○	○						
	70~100	√	√	√	×	Sewage		√			
Acetic acid (aerated)	10~50	√	√	√	√	Acid mineral water		√			
						Seawater		√	√	√	
						Industrial cooling water		√	√	√	√

Symbol description: √ Good corrosion resistance  
 ○ It's available, but it's rotten  
 × Not applicable

## Reference Table for Medium Selection of Chemical Pump

Corrosion data of nitrile - butadiene rubber Table 3											
Medium	Concentration	Temperature °C				Medium	Concentration	Temperature °C			
	%	25	40	66	90			%	25	40	60
Sulphuric acid	<10	√	√			Methanol		√	√	√	√
Nitric acid		×				Ethanol		○	○	○	○
Hydrochloric acid	<15	√	√	√	√	Glycol		√	√	√	√
	>15	○	○			Propanol		×			
Sulphuric acid	<45	○				Medium	Concentration	Temperature °C			
Acetic acid	<20	√	√	○	○		%	20	40	60	80
Sodium hydroxide	<20	√	√	○		Crude oil		√	√	√	√
	50	√	×			Crude oil (acid)		×			
Potassium hydroxide	<30	√	√	○	×	Gasoline		√	√	√	
Sodium chloride		√	√	√	√	Kerosene		√	√	√	√
						Beer		√	√	√	√
						Milk		√	√	√	√

Corrosion data of Ethylene Propylene Diene Monomer Table 4									
Medium	Concentration	Temperature °C			Medium	Concentration	Temperature °C		
	%	25	70	150			%	25	100
Sulphuric acid	0~50	○	○		Methanol		○	○	○
	50~70	○			Ethanol		○	○	○
	>70	×			Glycol		√	√	√
Nitric acid	10~30	○	○		Gasoline		×		
	>60	×			Kerosene		×		
Hydrochloric acid	<10	○	○	○	Salt water, sea water		√	√	√
	30	○			Sodium hydroxide		√	√	√
Phosphoric acid	0~85	√	√	√	Sodium chloride		√	√	√
Medium	Concentration	Temperature °C							
	%	25	100	150					
Formic acid	<85	√	√	√					
Acetic acid	<30	√	√						



Where there is Kaiquan, there is water!



上海凯泉泵业(集团)有限公司  
SHANGHAI KAIQUAN PUMP (GROUP) CO., LTD.

Company Address: No. 4255/4287, Caoan  
Highway, Jiading District, Shanghai  
Company Website: [www.Kaiquan.com.cn](http://www.Kaiquan.com.cn)  
Customer Service Hotline: 400-002-6600



YB/KAIQUAN KQWH/KQH-20190918